



蒙  
特  
纳  
利  
2  
0  
1  
9

# MONADRIVE

蒙纳智造 驱动未来



服务热线 Hotline  
**400-820-7566**

2019版  
苏州蒙特纳利驱动设备有限公司  
Suzhou Mona Drive Equipment Co.,Ltd  
地址：江苏省苏州市吴江区黎里镇长葑荡路66号  
No.66,Changfengdang Rd.,LiLi Town,Wujiang District,Suzhou215200,China  
电话/Tel: (+86) 0512 63080025 传真/Fax: (+86) 0512 63083998  
网址/Web:www.monadrive.cn



# 永磁同步无齿轮曳引机

Permanent Magnet Synchronous Gearless Traction Machine

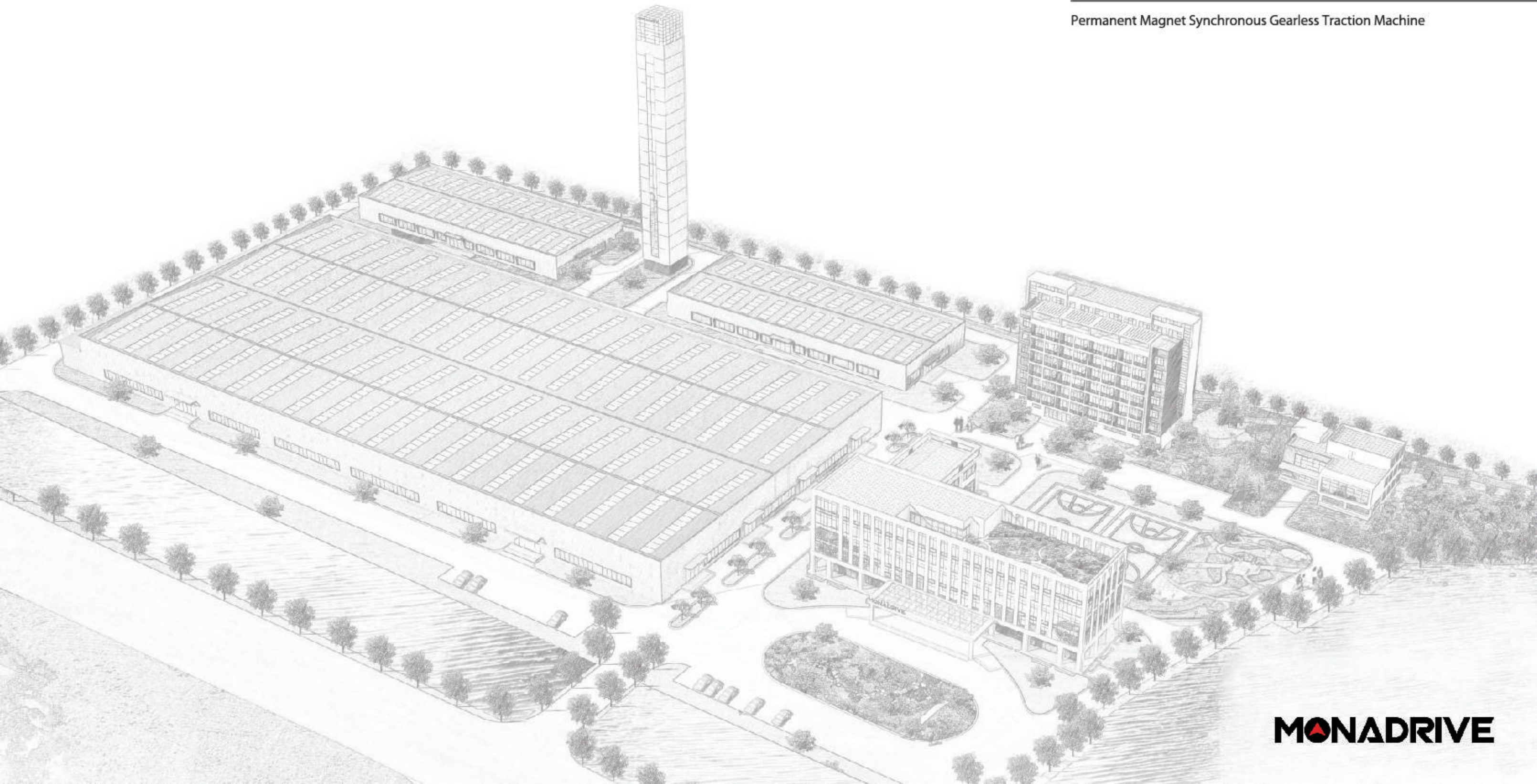

# MCK100

Permanent Magnet Synchronous Gearless Traction Machine  
永磁同步无齿轮曳引机

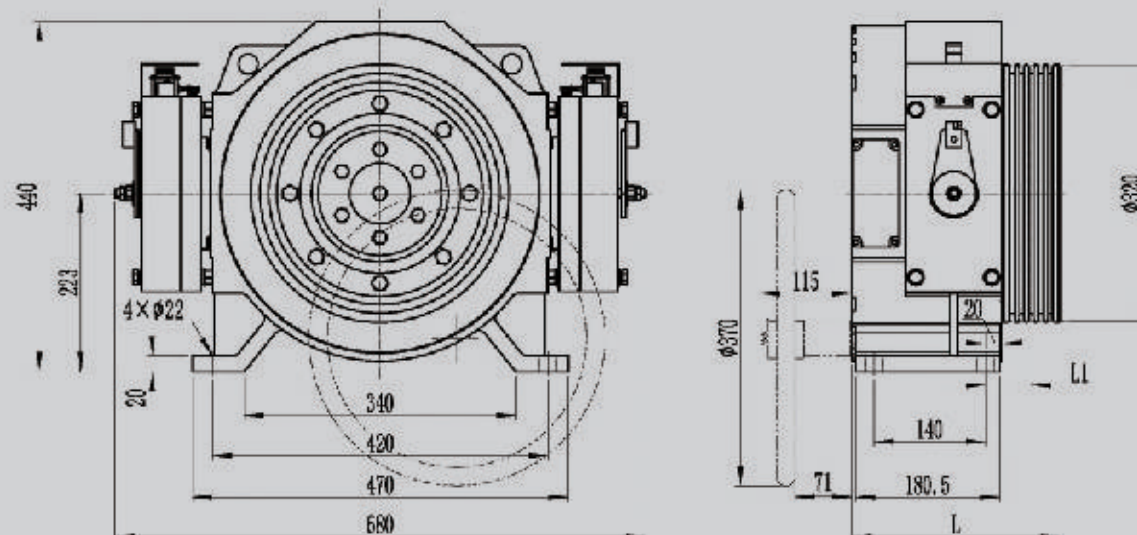
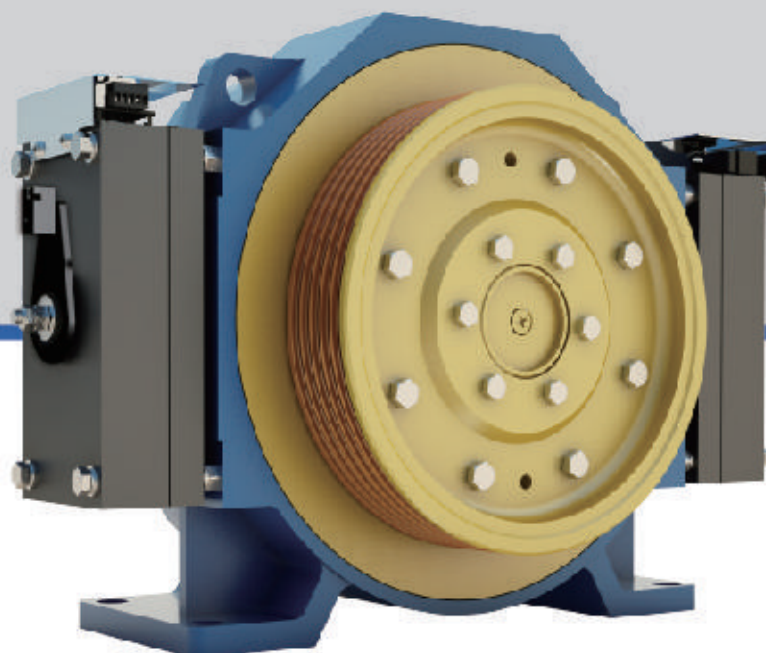

安装尺寸图  
DIMENSIONS

MCK100

## 规格表/SPEC.SHEET

型号	规格	额定载重	额定梯速	曳引轮节径	曳引轮绳槽	额定电流	额定功率	额定转速	额定频率	额定转矩	电机极数	L	L1	推荐切口角
Type	Spec	Elv Load	Elv Speed	Sheave Dia	Sheave Groove	Current	Power	Speed	Freq	Torque	Poles	mm	mm	Undercut Angle
		kg	m/s	mm		A	kW	r/min	Hz	N·m		mm	mm	°
MCK100	320-0.5A	320	0.5	320	3×Ø8×12	3	1.1	60	10.0	180	20	251	52	95
MCK100	320-0.63A	320	0.63	320	3×Ø8×12	3	1.4	75	12.5	180	20	251	52	
MCK100	320-1.0A	320	1.0	320	3×Ø8×12	5	2.2	119	19.8	180	20	251	52	
MCK100	320-1.5A	320	1.5	320	3×Ø8×12	8	3.4	179	29.8	180	20	251	52	
MCK100	450-0.5A	450	0.5	320	4×Ø8×12	5	1.5	60	10.0	240	20	251	52	
MCK100	450-0.63A	450	0.63	320	4×Ø8×12	5	1.9	75	12.5	240	20	251	52	
MCK100	450-1.0A	450	1.0	320	4×Ø8×12	7	3	119	19.8	240	20	251	52	
MCK100	450-1.5A	450	1.5	320	4×Ø8×12	11	4.5	179	29.8	240	20	251	52	
MCK100	450-1.75A	450	1.75	320	4×Ø8×12	11	5.3	209	34.8	240	20	251	52	
MCK100	630-0.5A	630	0.5	320	5×Ø8×12	7	2.1	60	10.0	340	20	261	57	
MCK100	630-0.63A	630	0.63	320	5×Ø8×12	7	2.7	75	12.5	340	20	261	57	
MCK100	630-1.0A	630	1.0	320	5×Ø8×12	10	4.2	119	19.8	340	20	261	57	
MCK100	630-1.5A	630	1.50	320	5×Ø8×12	16	6.4	179	29.8	340	20	261	57	
MCK100	630-1.6A	630	1.6	320	5×Ø8×12	16	6.8	191	31.8	340	20	261	57	
MCK100	630-1.75A	630	1.75	320	5×Ø8×12	16	7.4	209	34.8	340	20	261	57	

电源电压	Voltage	380V
悬挂比	Roping	2:1
绕绳方式	Wrap	单绕(Single)
额定载重	Elv. Load	( 320 ~ 630 ) kg
电梯速度	Elv. Speed	( 0.5 ~ 1.75 ) m/s
曳引轮节径	Sheave Diam	320mm
工作制	Duty	S5 - 40%ED
起动次数	Starts Per Hour	240st/h
最大轴静载	Max. Static Load	2500kg
自重	Weight	250kg
制动器	Brake	DC110V 2×1.3A
防护等级	IP Code	IP41
绝缘等级	Ins. Class	F

### 注 Remark:

- 1、本机型亦可用于无机房。 The machine can also be used for machine roomless.
- 2、制动器可选配交流220V整流模块。 Optional AC 220V rectifier for brake.
- 3、样本切口角为推荐值，可根据实际工况要求选择切口角度。 The above is recommended value of cut angle, it's optional according to practical condition.

# MCK200

Permanent Magnet Synchronous Gearless Traction Machine  
永磁同步无齿轮曳引机

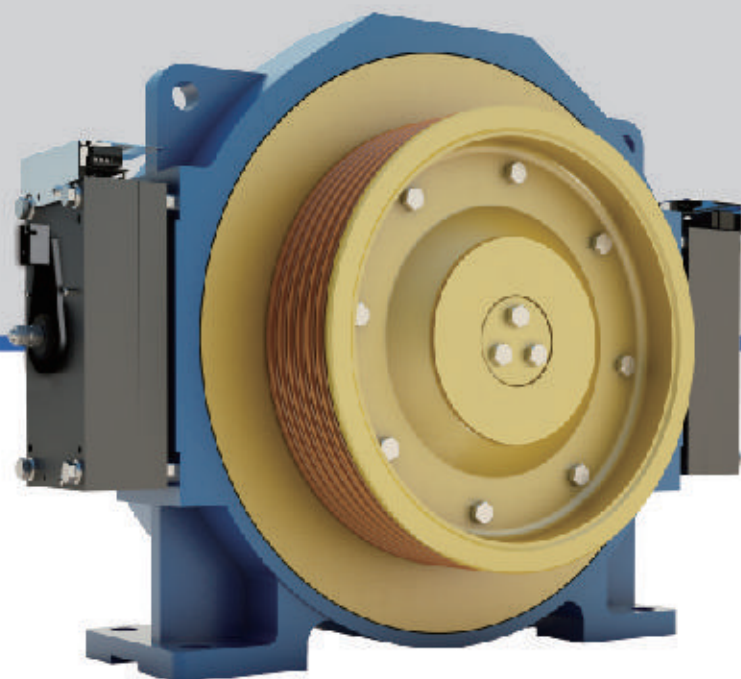

安装尺寸图  
DIMENSIONS

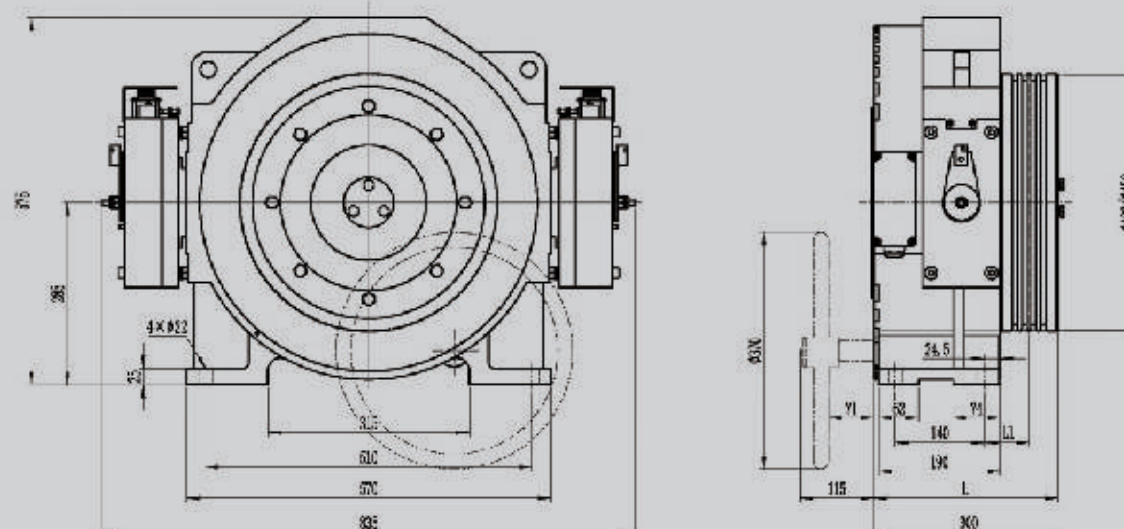

MCK200

## 规格表/SPEC.SHEET

型号 Type	规格 Spec	额定载重 Elv Load	额定梯速 Elv Speed	曳引轮节径 Sheave Dia	曳引轮绳槽 Sheave Groove	额定电流 Current	额定功率 Power	额定转速 Speed	额定频率 Freq	额定转矩 Torque	电机极数 Poles	L	L1	推荐切口角 Undercut Angle
		kg	m/s	mm		A	kW	r/min	Hz	N·m		mm	mm	°
MCK200	630-0.5A	630	0.5	400	4×Φ10×15	6	2.2	48	12.8	430	32	288	69.5	95
MCK200	630-0.63A	630	0.63	400	4×Φ10×15	6	2.7	60	16.0	430	32	288	69.5	
MCK200	630-1.0A	630	1.0	400	4×Φ10×15	10	4.3	95	25.3	430	32	288	69.5	
MCK200	630-1.5A	630	1.5	400	4×Φ10×15	14	6.4	143	38.1	430	32	288	69.5	
MCK200	630-1.6A	630	1.6	400	4×Φ10×15	16	6.9	153	40.8	430	32	288	69.5	
MCK200	630-1.75A	630	1.75	400	4×Φ10×15	16	7.5	167	44.5	430	32	288	69.5	
MCK200	630-2.0A	630	2.0	400	4×Φ10×15	18	8.6	191	50.9	430	32	288	69.5	
MCK200	630-2.0B	630	2.0	450	4×Φ10×15	18	8.5	170	45.3	480	32	288	69.5	
MCK200	800-0.5A	800	0.5	400	5×Φ10×15	8	2.7	48	12.8	540	32	288	69.5	
MCK200	800-0.63A	800	0.63	400	5×Φ10×15	8	3.4	60	16.0	540	32	288	69.5	
MCK200	800-1.0A	800	1.0	400	5×Φ10×15	12	5.4	95	25.3	540	32	288	69.5	
MCK200	800-1.5A	800	1.5	400	5×Φ10×15	18	8.1	143	38.1	540	32	288	69.5	
MCK200	800-1.6A	800	1.6	400	5×Φ10×15	20	8.7	153	40.8	540	32	288	69.5	
MCK200	800-1.75A	800	1.75	400	5×Φ10×15	20	9.4	167	44.5	540	32	288	69.5	
MCK200	800-2.0A	800	2.0	400	5×Φ10×15	23	10.8	191	50.9	540	32	288	69.5	
MCK200	800-2.0B	800	2.0	450	5×Φ10×15	23	10.7	170	45.3	600	32	288	69.5	
MCK200	800-2.5A	800	2.5	400	6×Φ10×15	28	13.5	239	63.7	540	32	300	75.5	
MCK200	800-2.5B	800	2.5	450	5×Φ10×15	29	13.3	212	56.5	600	32	288	69.5	
MCK200	1000-0.5A	1000	0.5	400	5×Φ10×15	10	3.4	48	12.8	670	32	288	69.5	
MCK200	1000-0.63A	1000	0.63	400	5×Φ10×15	10	4.2	60	16.0	670	32	288	69.5	
MCK200	1000-1.0A	1000	1.0	400	5×Φ10×15	15	6.7	95	25.3	670	32	288	69.5	
MCK200	1000-1.5A	1000	1.5	400	5×Φ10×15	23	10.0	143	38.1	670	32	288	69.5	
MCK200	1000-1.6A	1000	1.6	400	5×Φ10×15	26	10.7	153	40.8	670	32	288	69.5	
MCK200	1000-1.75A	1000	1.75	400	5×Φ10×15	26	11.7	167	44.5	670	32	288	69.5	
MCK200	1000-2.0A	1000	2.0	400	5×Φ10×15	28	13.4	191	50.9	670	32	288	69.5	
MCK200	1000-2.0B	1000	2.0	450	5×Φ10×15	28	13.4	170	45.3	750	32	288	69.5	
MCK200	1000-2.5A	1000	2.5	400	6×Φ10×15	34	16.8	239	63.7	670	32	300	75.5	
MCK200	1000-2.5B	1000	2.5	450	6×Φ10×15	36	16.6	212	56.5	750	32	300	75.5	
MCK200	1150-0.5A	1150	0.5	400	5×Φ10×15	12	3.9	48	12.8	780	32	288	69.5	
MCK200	1150-0.63A	1150	0.63	400	5×Φ10×15	12	4.9	60	16.0	780	32	288	69.5	
MCK200	1150-1.0A	1150	1.0	400	5×Φ10×15	17	7.8	95	25.3	780	32	288	69.5	
MCK200	1150-1.5A	1150	1.5	400	6×Φ10×15	29	11.7	143	38.1	780	32	300	75.5	
MCK200	1150-1.6A	1150	1.6	400	6×Φ10×15	29	12.5	153	40.8	780	32	300	75.5	
MCK200	1150-1.75A	1150	1.75	400	6×Φ10×15	29	13.6	167	44.5	780	32	300	75.5	
MCK200	1150-2.0A	1150	2.0	400	6×Φ10×15	33	15.6	191	50.9	780	32	300	75.5	

注 Remark:

1. 本机型亦可用于无机房。 The machine can also be used for machine roomless.
2. 制动器可选配交流220V整流模块。 Optional AC 220V rectifier for brake.
3. 样本切口角为推荐值, 可根据实际工况要求选择切口角度。 The above is recommended value of cut angle, it's optional according to practical condition.

电源电压	Voltage	380V
悬挂比	Roping	2:1
绕绳方式	Wrap	单绕(Single)
额定载重	Elv. Load	(630 ~ 1150)kg
电梯速度	Elv. Speed	(0.5 ~ 2.5)m/s
曳引轮节径	Sheave Diam	400mm/450mm
工作制	Duty	S5 - 40%ED
起动次数	Starts Per Hour	240st/h
最大轴静载	Max. Static Load	4000kg
自重	Weight	350kg
制动器	Brake	DC110V 2×1.3A
防护等级	IP Code	IP41
绝缘等级	Ins. Class	F

# MCK300

Permanent Magnet Synchronous Gearless Traction Machine  
永磁同步无齿轮曳引机

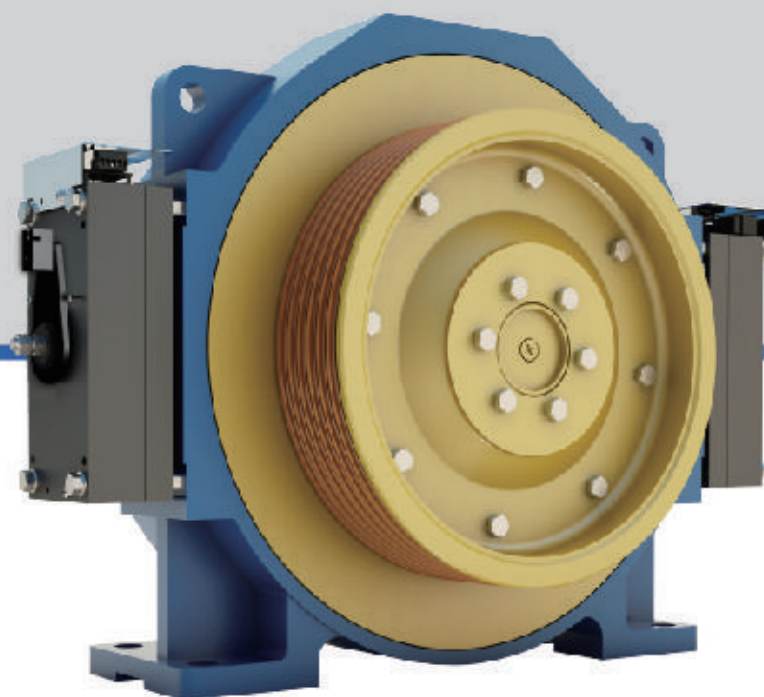

安装尺寸图  
DIMENSIONS

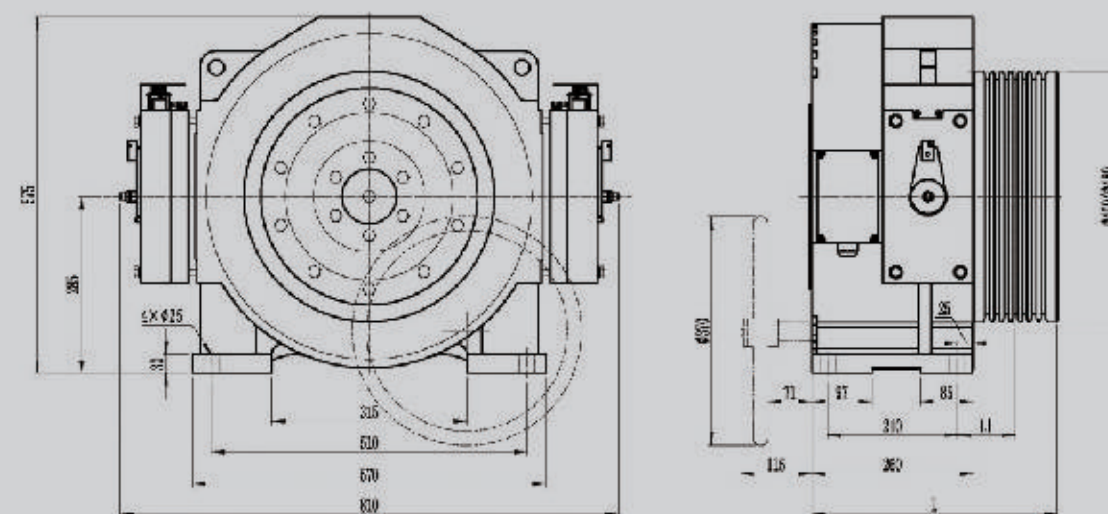

MCK300

## 规格表/SPEC.SHEET

型号	规格	额定载重	额定梯速	曳引轮直径	曳引轮绳槽	额定电流	额定功率	额定转速	额定频率	额定转矩	电机极数	L	L1	推荐切口角
Type	Spec	Elv Load	Elv Speed	Sheave Dia	Sheave Groove	Current	Power	Speed	Freq	Torque	Poles	mm	mm	UndercutAngle
		kg	m/s	mm		A	kW	r/min	Hz	N·m				°
MCK300	1250-0.5A	1250	0.5	400	6×Φ10×15	13	4.3	48	12.8	850	32	381	86	
MCK300	1250-0.63A	1250	0.63	400	6×Φ10×15	13	5.3	60	16.0	850	32	381	86	
MCK300	1250-1.0A	1250	1.0	400	6×Φ10×15	20	8.5	95	25.3	850	32	381	86	
MCK300	1250-1.5A	1250	1.5	400	6×Φ10×15	34	12.7	143	38.1	850	32	381	86	
MCK300	1250-1.6A	1250	1.6	400	6×Φ10×15	34	13.6	153	40.8	850	32	381	86	
MCK300	1250-1.75A	1250	1.75	400	6×Φ10×15	34	14.9	167	44.5	850	32	381	86	
MCK300	1250-2.0A	1250	2.0	400	6×Φ10×15	38	17.0	191	50.9	850	32	381	86	
MCK300	1250-2.5A	1250	2.5	480	7×Φ10×15	45	21.3	199	53.1	1020	32	381	86	
MCK300	1350-0.5A	1350	0.5	400	7×Φ10×15	14	4.6	48	12.8	920	32	381	86	
MCK300	1350-0.63A	1350	0.63	400	7×Φ10×15	14	5.8	60	16.0	920	32	381	86	
MCK300	1350-1.0A	1350	1.0	400	7×Φ10×15	21	9.2	95	25.3	920	32	381	86	
MCK300	1350-1.5A	1350	1.5	400	7×Φ10×15	36	13.8	143	38.1	920	32	381	86	95
MCK300	1350-1.6A	1350	1.6	400	7×Φ10×15	36	14.7	153	40.8	920	32	381	86	
MCK300	1350-1.75A	1350	1.75	400	7×Φ10×15	36	16.1	167	44.5	920	32	381	86	
MCK300	1350-2.0A	1350	2.0	400	7×Φ10×15	40	18.4	191	50.9	920	32	381	86	
MCK300	1350-2.5A	1350	2.5	480	7×Φ10×15	52	22.9	199	53.1	1100	32	381	86	
MCK300	1600-0.5A	1600	0.5	400	7×Φ10×15	18	5.6	48	12.8	1110	32	381	86	
MCK300	1600-0.63A	1600	0.63	400	7×Φ10×15	18	7.0	60	16.0	1110	32	381	86	
MCK300	1600-1.0A	1600	1.0	400	7×Φ10×15	26	11.0	95	25.3	1110	32	381	86	
MCK300	1600-1.5A	1600	1.5	400	8×Φ10×15	41	16.6	143	38.1	1110	32	396	93.5	
MCK300	1600-1.6A	1600	1.6	400	8×Φ10×15	41	17.8	153	40.8	1110	32	396	93.5	
MCK300	1600-1.75A	1600	1.75	400	8×Φ10×15	41	19.4	167	44.5	1110	32	396	93.5	
MCK300	1600-2.0A	1600	2.0	400	8×Φ10×15	47	22.2	191	50.9	1110	32	396	93.5	

注 Remark:

- 1、本机型亦可用于无机房。The machine can also be used for machine roomless.
- 2、制动器可选配交流220V整流模块。Optional AC 220V rectifier for brake.
- 3、样本切口角为推荐值，可根据实际工况要求选择切口角度。The above is recommended value of cut angle, it's optional according to practical condition.

电源电压	Voltage	380V
悬挂比	Roping	2:1
绕绳方式	Wrap	单绕(Single)
额定载重	Elv. Load	(1250 ~ 1600)kg
电梯速度	Elv. Speed	(0.5 ~ 2.5)m/s
曳引轮直径	Sheave Diam	400mm / 480mm
工作制	Duty	S5 - 40%ED
起动次数	Starts Per Hour	240st/h
最大轴静载	Max. Static Load	6000kg
自重	Weight	520kg
制动器	Brake	DC110V 2×1.6A
防护等级	IP Code	IP41
绝缘等级	Ins. Class	F

# MCK500

Permanent Magnet Synchronous Gearless Traction Machine  
永磁同步无齿轮曳引机

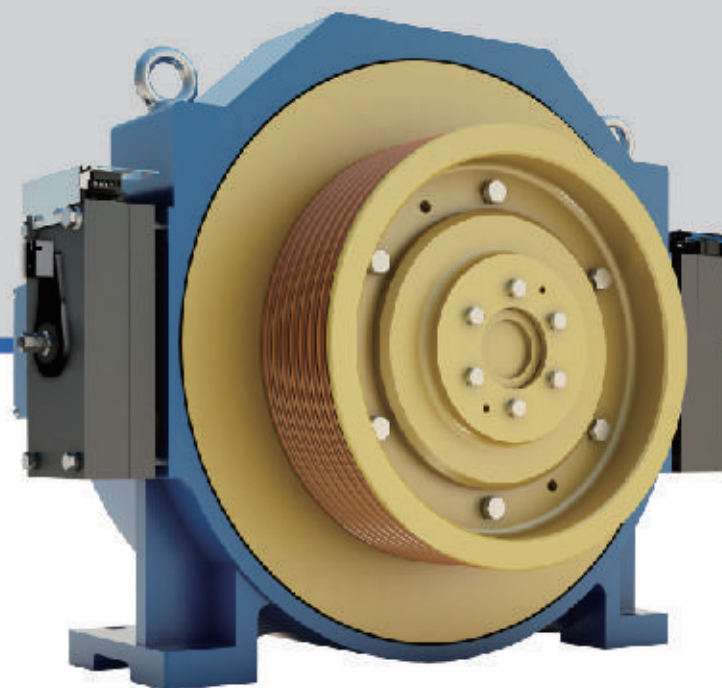

安装尺寸图  
DIMENSIONS

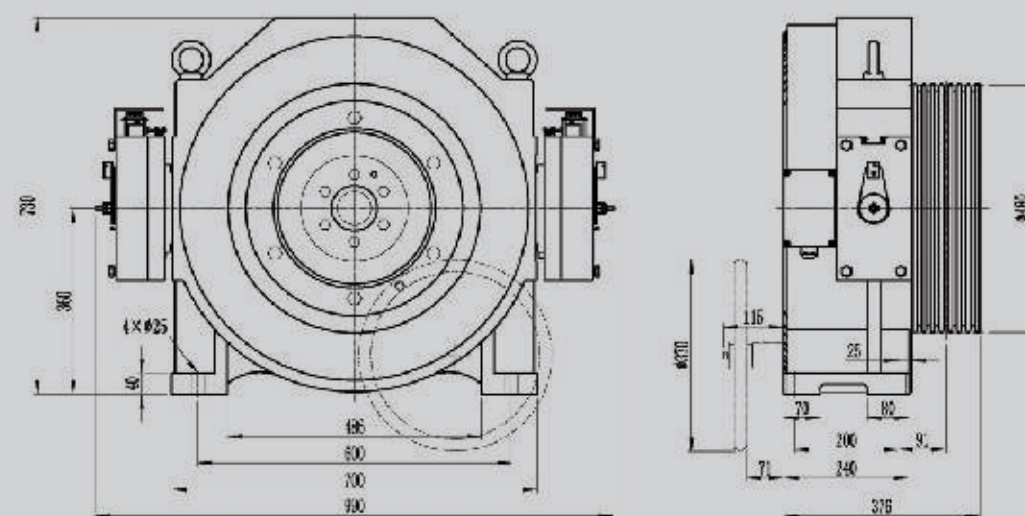

MCK500

## 规格表/SPEC.SHEET

型号	规格	额定载重	额定梯速	曳引轮节径	曳引轮绳槽	额定电流	额定功率	额定转速	额定频率	额定转矩	电机极数	推荐切口角
Type	Spec	Elv Load	Elv Speed	Sheave Dia	Sheave Groove	Current	Power	Speed	Freq	Torque	Poles	Undercut Angle
		kg	m/s	mm		A	kW	r/min	Hz	N·m		°
MCK500	1600-0.5A	1600	0.5	480	6×Φ12×17	18	5.6	40	16.0	1330	48	95
MCK500	1600-0.63A	1600	0.63	480	6×Φ12×17	18	7.0	50	20.0	1330	48	
MCK500	1600-1.0A	1600	1.0	480	6×Φ12×17	27	11.1	80	32.0	1330	48	
MCK500	1600-1.5A	1600	1.5	480	6×Φ12×17	44	16.6	119	47.6	1330	48	
MCK500	1600-1.6A	1600	1.6	480	6×Φ12×17	44	17.7	127	50.8	1330	48	
MCK500	1600-1.75A	1600	1.75	480	6×Φ12×17	44	19.4	139	55.6	1330	48	
MCK500	1600-2.0A	1600	2.0	480	6×Φ12×17	49	22.1	159	63.6	1330	48	
MCK500	1600-2.5A	1600	2.5	480	6×Φ12×17	60	27.7	199	79.6	1330	48	
MCK500	2000-0.5A	2000	0.5	480	7×Φ12×17	22	7.0	40	16.0	1660	48	
MCK500	2000-0.63A	2000	0.63	480	7×Φ12×17	22	8.7	50	20.0	1660	48	
MCK500	2000-1.0A	2000	1.0	480	7×Φ12×17	31	13.9	80	32.0	1660	48	
MCK500	2000-1.5A	2000	1.5	480	7×Φ12×17	53	20.7	119	47.6	1660	48	
MCK500	2000-1.6A	2000	1.6	480	7×Φ12×17	53	22.1	127	50.8	1660	48	
MCK500	2000-1.75A	2000	1.75	480	7×Φ12×17	53	24.2	139	55.6	1660	48	
MCK500	2000-2.0A	2000	2.0	480	7×Φ12×17	61	27.6	159	63.6	1660	48	

注 Remark:

1. 本机型亦可用于无机房。 The machine can also be used for machine roomless.
2. 制动器可选配交流220V整流模块。 Optional AC 220V rectifier for brake.
3. 样本切口角为推荐值,可根据实际工况要求选择切口角度。 The above is recommended value of cut angle,it's optional according to practical condition.

电源电压	Voltage	380V
悬挂比	Roping	2:1
绕绳方式	Wrap	单绕(Single)
额定载重	Elv. Load	(1600 ~ 2000)kg
电梯速度	Elv. Speed	(0.5 ~ 2.5)m/s
曳引轮节径	Sheave Diam	480mm
工作制	Duty	S5 - 40%ED
起动次数	Starts Per Hour	240st/h
最大轴静载	Max. Static Load	10000kg
自重	Weight	765kg
制动器	Brake	DC110V 2×1.2A
防护等级	IP Code	IP41
绝缘等级	Ins. Class	F

# MONA180

Permanent Magnet Synchronous Gearless Traction Machine  
永磁同步无齿轮曳引机

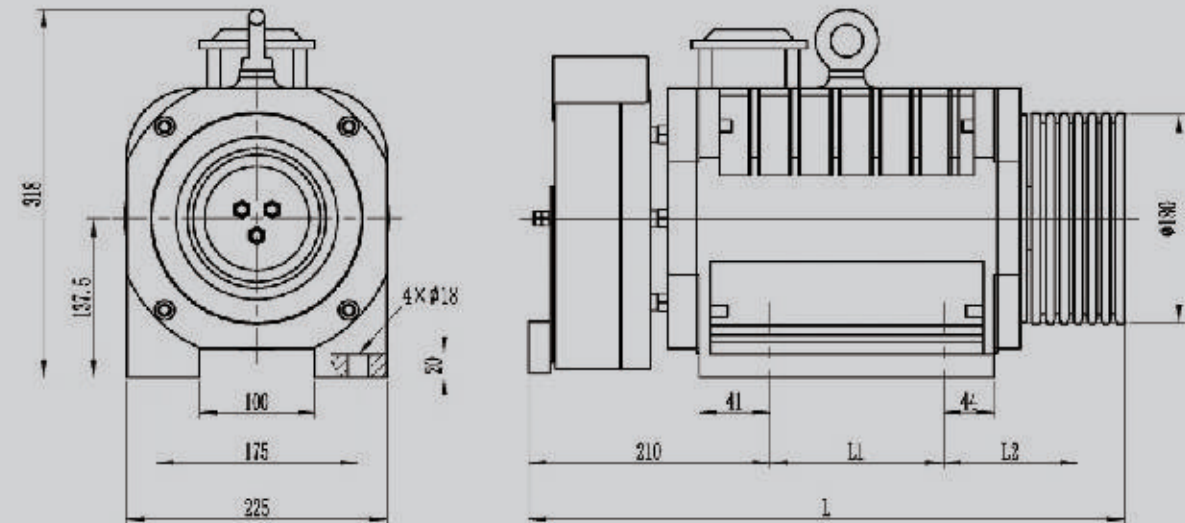
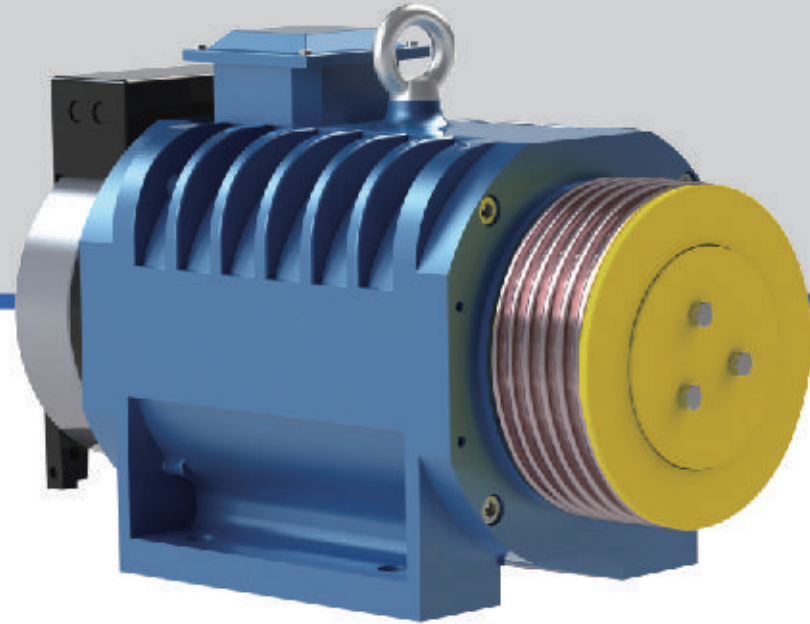

安装尺寸图  
DIMENSIONS

MONA180

## 规格表/SPEC.SHEET

型号	悬挂比	规格	额定载重	额定转速	曳引轮节径	曳引轮槽槽	电源电压	额定电流	额定功率	额定转速	额定频率	额定转矩	电机极数	L	L1	L2	推荐切口角
Type	Roping	Spec	Elv Load	Elv Speed	Sheave Dia	Sheave Groove	Voltage	Current	Power	Speed	Freq	Torque	Poles	mm	mm	mm	Undercut Angle
			kg	m/s	mm		V	A	kW	r/min	Hz	N·m					°
MONA180	2:1	320-0.4A	320	0.4	180	4×Φ6×12	220 380	6 4	0.9	85	11.3	100	16	505	150	110.5	90
MONA180	2:1	320-0.5A	320	0.5	180	4×Φ6×12	220 380	6 4	1.1	106	14.1	100	16	505	150	110.5	
MONA180	2:1	320-0.63A	320	0.63	180	4×Φ6×12	220 380	6 4	1.4	134	17.9	100	16	505	150	110.5	
MONA180	2:1	320-1.0A	320	1.0	180	4×Φ6×12	220 380	9 6	2.2	212	28.3	100	16	505	150	110.5	
MONA180	2:1	400-0.4A	400	0.4	180	5×Φ6×12	220 380	7 4	1.1	85	11.3	120	16	505	150	110.5	
MONA180	2:1	400-0.5A	400	0.5	180	5×Φ6×12	220 380	7 5	1.3	106	14.1	120	16	505	150	110.5	
MONA180	2:1	400-0.63A	400	0.63	180	5×Φ6×12	220 380	7 5	1.8	134	17.9	130	16	505	150	110.5	
MONA180	2:1	400-1.0A	400	1.0	180	5×Φ6×12	220 380	11 7	2.7	212	28.3	120	16	505	150	110.5	
MONA180	2:1	450-0.4A	450	0.4	180	5×Φ6×12	220 380	8 5	1.2	85	11.3	140	16	505	150	110.5	
MONA180	2:1	450-0.5A	450	0.5	180	5×Φ6×12	220 380	8 6	1.6	106	14.1	140	16	505	150	110.5	
MONA180	2:1	450-0.63A	450	0.63	180	5×Φ6×12	220 380	8 6	2	134	17.9	145	17	505	150	110.5	
MONA180	2:1	450-1.0A	450	1.0	180	5×Φ6×12	220 380	13 8	3.1	212	28.3	140	16	505	150	110.5	
MONA180	2:1	630-0.63A	630	0.63	180	6×Φ6×12	220 380	11 7	2.7	134	17.9	190	16	585	220	116.5	
MONA180	2:1	630-1.0A	630	1.0	180	6×Φ6×12	220 380	18 11	4.2	212	28.3	190	16	585	220	116.5	

注 Remark:

- 1、本机型用于无机房。The machine is used for machine roomless.
- 2、样本切口角为推荐值，可根据实际工况要求选择切口角度。  
The above is recommended value of cut angle, it's optional according to practical condition.

电源电压	Voltage	220V / 380V
悬挂比	Roping	2:1
绕绳方式	Wrap	单绕(Single)
额定载重	Elv. Load	(320 ~ 630)kg
电梯速度	Elv. Speed	(0.4 ~ 1.0)m/s
曳引轮节径	Sheave Diam	180mm
工作制	Duty	S5 - 40%ED
起动次数	Starts Per Hour	180st/h
最大轴静载	Max. Static Load	2500kg
自重	Weight	140kg
制动器	Brake	DC110V 2×1.2A
防护等级	IP Code	IP41
绝缘等级	Ins. Class	F

# MONA180A

Permanent Magnet Synchronous Gearless Traction Machine  
永磁同步无齿轮曳引机

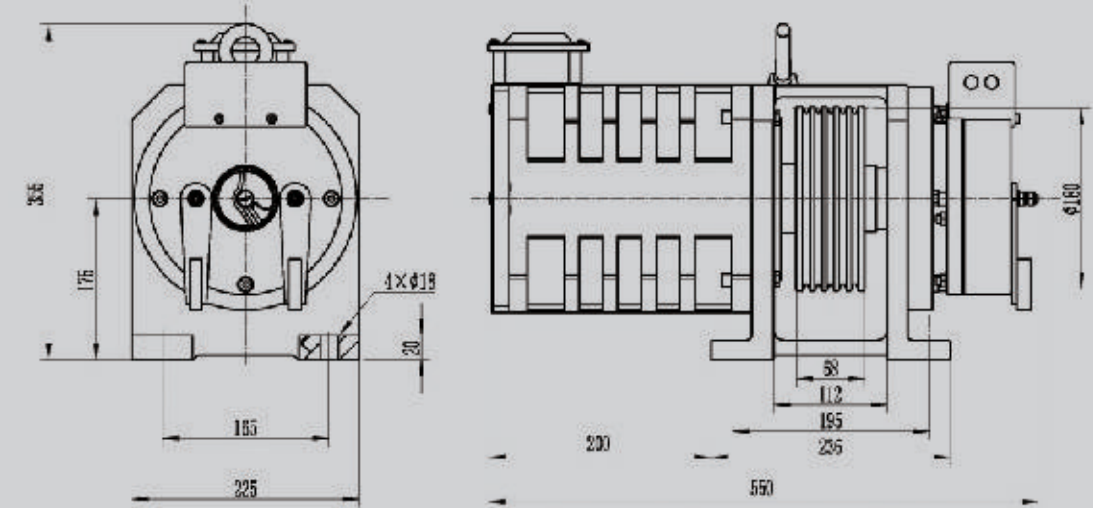
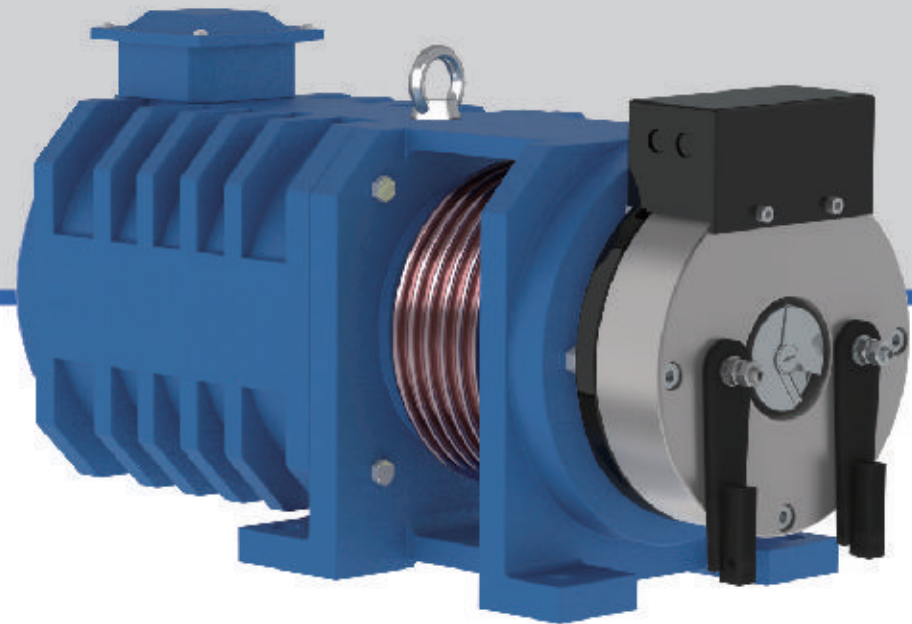

安装尺寸图  
DIMENSIONS

MONA180A

## 规格表/SPEC.SHEET

型号	悬挂比	规格	额定载重	额定梯速	曳引轮节径	曳引轮绳槽	电源电压	额定电流	额定功率	额定转速	额定频率	额定转矩	电机极数	推荐切口角
Type	Roping	Spec	Elv Load	Elv Speed	Sheave Dia	Sheave Groove	Voltage	Current	Power	Speed	Freq	Torque	Poles	Undercut Angle
			kg	m/s	mm		V	A	kW	r/min	Hz	N·m		°
MONA180A	2:1	320-0.4A	320	0.4	180	4×Φ6×12	220	6	0.9	85	11.3	100	16	90
							380	4						
MONA180A	2:1	320-0.5A	320	0.5	180	4×Φ6×12	220	6	1.1	106	14.1	100	16	
							380	4						
MONA180A	2:1	320-0.63A	320	0.63	180	4×Φ6×12	220	6	1.4	134	17.9	100	16	
							380	4						
MONA180A	2:1	320-1.0A	320	1.0	180	4×Φ6×12	220	9	2.2	212	28.3	100	16	
							380	6						
MONA180A	2:1	400-0.4A	400	0.4	180	5×Φ6×12	220	7	1.1	85	11.3	120	16	
							380	4						
MONA180A	2:1	400-0.5A	400	0.5	180	5×Φ6×12	220	7	1.3	106	14.1	120	16	
							380	5						
MONA180A	2:1	400-0.63A	400	0.63	180	5×Φ6×12	220	7	1.8	134	17.9	130	16	
							380	5						
MONA180A	2:1	400-1.0A	400	1.0	180	5×Φ6×12	220	11	2.7	212	28.3	120	16	
							380	7						
MONA180A	2:1	450-0.4A	450	0.4	180	5×Φ6×12	220	8	1.2	85	11.3	140	16	
							380	5						
MONA180A	2:1	450-0.5A	450	0.5	180	5×Φ6×12	220	8	1.6	106	14.1	140	16	
							380	6						
MONA180A	2:1	450-0.63A	450	0.63	180	5×Φ6×12	220	8	2	134	17.9	140	16	
							380	6						
MONA180A	2:1	450-1.0A	450	1.0	180	5×Φ6×12	220	13	3.1	212	28.3	140	16	
							380	8						

注 Remark:

1、本机型用于无机房。The machine is used for machine roomless.

2、样本切口角为推荐值，可根据实际工况要求选择切口角度。

The above is recommended value of cut angle, it's optional according to practical condition.

电源电压	Voltage	220V / 380V
悬挂比	Roping	2:1
绕绳方式	Wrap	单绕(Single)
额定载重	Elv. Load	(320 ~ 450)kg
电梯速度	Elv. Speed	(0.4 ~ 1.0)m/s
曳引轮节径	Sheave Diam	180mm
工作制	Duty	S5 - 40%ED
起动次数	Starts Per Hour	180st/h
最大轴静载	Max. Static Load	2000kg
自重	Weight	140kg
制动器	Brake	DC110V 2×1.2A
防护等级	IP Code	IP41
绝缘等级	Ins. Class	F



# MONA200

Permanent Magnet Synchronous Gearless Traction Machine  
永磁同步无齿轮曳引机

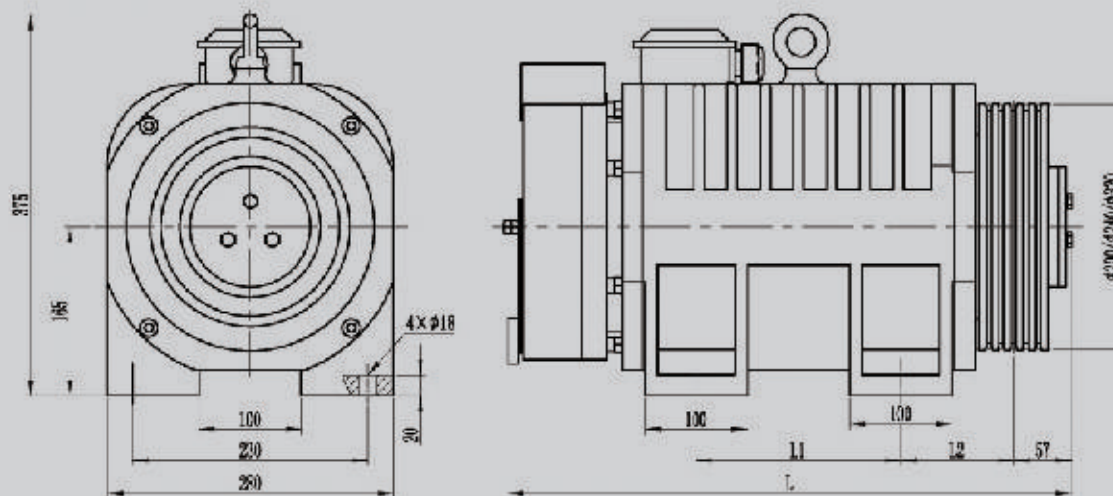
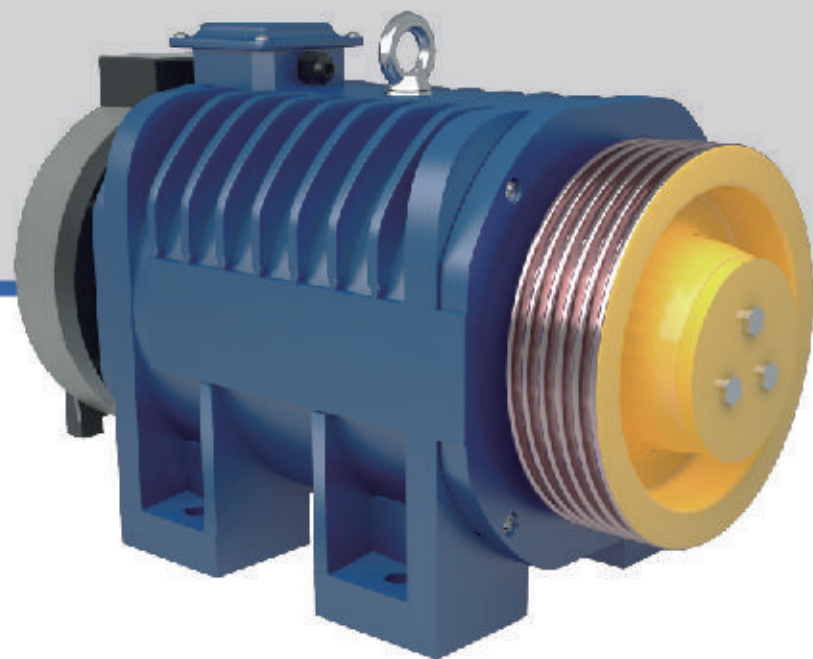

安装尺寸图  
DIMENSIONS

MONA200

## 规格表/SPEC.SHEET

型号 Type	悬挂比 Roping	规格 Spec	额定载重 Elv Load kg	额定速度 Elv Speed m/s	曳引轮节径 Sheave Dia mm	曳引轮绳槽 Sheave Groove	电源电压 Voltage V	额定电流 Current A	额定功率 Power kW	额定转速 Speed r/min	额定频率 Freq Hz	额定转矩 Torque N·m	电机极数 Poles	L	L1	L2	推荐切口角 Undercut Angle °
MONA200	2:1	320-0.4A	320	0.4	200	3 × Ø8 × 12	220 380	4 2	0.9	76	15.2	110	24	430	100	100.5	90
MONA200	2:1	400-0.4A	400	0.4	200	4 × Ø8 × 12	220 380	5 3	1.1	76	15.2	140	24	430	100	100.5	
MONA200	2:1	450-0.4A	450	0.4	200	4 × Ø8 × 12	220 380	6 4	1.2	76	15.2	150	24	430	100	100.5	
MONA200	2:1	320-0.4B	320	0.4	240	3 × Ø8 × 12	220 380	5 3	0.9	64	12.8	130	24	430	100	100.5	
MONA200	2:1	400-0.4B	400	0.4	240	4 × Ø8 × 12	220 380	6 3	1.1	64	12.8	160	24	430	100	100.5	
MONA200	2:1	450-0.4B	450	0.4	240	4 × Ø8 × 12	220 380	7 5	1.2	64	12.8	180	24	430	100	100.5	
MONA200	1:1	320-0.4C	320	0.4	200	4 × Ø8 × 12	220 380	5 3	0.9	38	5.1	220	16	520	150	110.5	
MONA200	1:1	400-0.4C	400	0.4	200	5 × Ø8 × 12	220 380	6 4	1.1	38	5.1	270	16	520	150	110.5	
MONA200	1:1	450-0.4C	450	0.4	200	5 × Ø8 × 12	220 380	7 5	1.2	38	5.1	300	16	520	150	110.5	
MONA200	1:1	320-0.4D	320	0.4	240	4 × Ø8 × 12	220 380	6 4	0.9	32	4.3	260	16	520	150	110.5	
MONA200	1:1	400-0.4D	400	0.4	240	5 × Ø8 × 12	220 380	7 5	1.1	32	4.3	320	16	520	150	110.5	
MONA200	1:1	450-0.4D	450	0.4	240	5 × Ø8 × 12	220 380	8 6	1.2	32	4.3	360	16	570	200	110.5	
MONA200	2:1	320-0.5A	320	0.5	320	3 × Ø8 × 12	380	4	1.1	60	12.0	170	24	430	100	100.5	
MONA200	2:1	320-0.63A	320	0.63	320	3 × Ø8 × 12	380	4	1.3	75	15.0	170	24	430	100	100.5	
MONA200	2:1	320-1.0A	320	1.0	320	3 × Ø8 × 12	380	6	2.1	119	23.8	170	24	430	100	100.5	
MONA200	2:1	400-0.5A	400	0.5	320	4 × Ø8 × 12	380	5	1.4	60	12.0	220	24	520	150	110.5	
MONA200	2:1	400-0.63A	400	0.63	320	4 × Ø8 × 12	380	5	1.7	75	15.0	220	24	520	150	110.5	
MONA200	2:1	400-1.0A	400	1.0	320	4 × Ø8 × 12	380	8	2.7	119	23.8	220	24	520	150	110.5	
MONA200	2:1	450-0.5A	450	0.5	320	4 × Ø8 × 12	380	6	1.5	60	12.0	240	24	520	150	110.5	
MONA200	2:1	450-0.63A	450	0.63	320	4 × Ø8 × 12	380	6	1.9	75	15.0	240	24	520	150	110.5	
MONA200	2:1	450-1.0A	450	1.0	320	4 × Ø8 × 12	380	9	3	119	23.8	240	24	520	150	110.5	
MONA200	2:1	630-0.5A	630	0.5	320	5 × Ø8 × 12	380	8	2.1	60	12.0	340	24	570	200	110.5	
MONA200	2:1	630-0.63A	630	0.63	320	5 × Ø8 × 12	380	8	2.7	75	15.0	340	24	570	200	110.5	
MONA200	2:1	630-1.0A	630	1.0	320	5 × Ø8 × 12	380	11	4.2	119	23.8	340	24	570	200	110.5	
MONA200	2:1	630-1.5A	630	1.5	320	5 × Ø8 × 12	380	16	6.4	179	35.8	340	24	570	200	110.5	

注 Remark:

1. 本机用于无机房。The machine is used for machine roomless.

2. 样本切口角为推荐值，可根据实际工况要求选择切口角度。

The above is recommended value of cut angle, it's optional according to practical condition.

电源电压	Voltage	220V / 380V
悬挂比	Roping	2:1 / 1:1
绕绳方式	Wrap	单绕(Single)
额定载重	Elv. Load	(320 ~ 630)kg
电梯速度	Elv. Speed	(0.4 ~ 1.5)m/s
曳引轮节径	Sheave Diam	200mm/240mm/320mm
工作制	Duty	S5 - 40%ED
起动次数	Starts Per Hour	180st/h
最大轴静载	Max. Static Load	2500kg
自重	Weight	210kg
制动器	Brake	DC110V 2.5A
防护等级	IP Code	IP41
绝缘等级	Ins. Class	F

# MONA200A

Permanent Magnet Synchronous Gearless Traction Machine  
永磁同步无齿轮曳引机

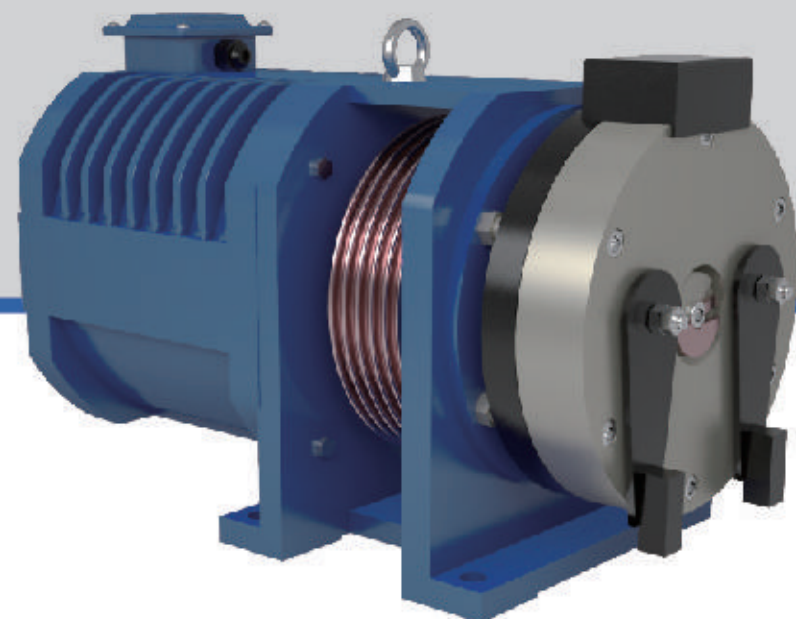

安装尺寸图  
DIMENSIONS

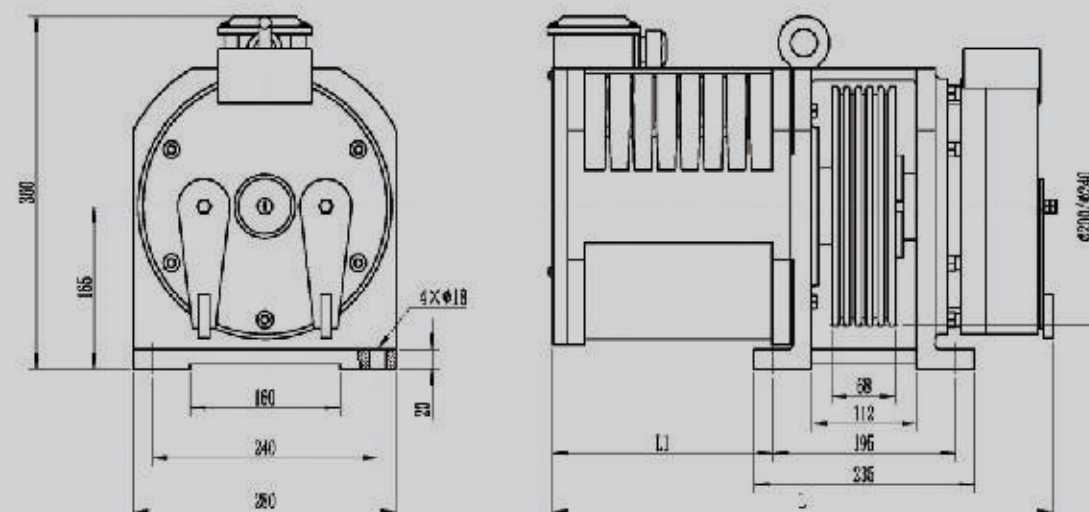

MONA200A

## 规格表/SPEC.SHEET

型号	悬挂比	规格	额定载重	额定梯速	曳引轮节径	曳引轮绳槽	电源电压	额定电流	额定功率	额定转速	额定频率	额定转矩	电机极数	L	L1	推荐切口角
Type	Roping	Spec	Elv Load	Elv Speed	Sheave Dia	Sheave Groove	Voltage	Current	Power	Speed	Freq	Torque	Poles	mm	mm	Undercut Angle
			kg	m/s	mm		V	A	kW	r/min	Hz	N·m		mm	mm	°
MONA200A	2:1	320-0.4A	320	0.4	200	3×Φ8×12	220	4	0.9	76	15.2	110	24	470	170	90
							380	2								
MONA200A	2:1	400-0.4A	400	0.4	200	4×Φ8×12	220	5	1.1	76	15.2	140	24	470	170	
							380	3								
MONA200A	2:1	450-0.4A	450	0.4	200	4×Φ8×12	220	6	1.2	76	15.2	150	24	470	170	
							380	4								
MONA200A	2:1	320-0.4B	320	0.4	240	3×Φ8×12	220	5	0.9	64	12.8	130	24	470	170	
							380	3								
MONA200A	2:1	400-0.4B	400	0.4	240	4×Φ8×12	220	6	1.1	64	12.8	160	24	470	170	
							380	3								
MONA200A	2:1	450-0.4B	450	0.4	240	4×Φ8×12	220	7	1.2	64	12.8	180	24	470	170	
							380	5								
MONA200A	1:1	320-0.4C	320	0.4	200	4×Φ8×12	220	5	0.9	38	5.1	220	16	560	240	
							380	3								
MONA200A	1:1	400-0.4C	400	0.4	200	5×Φ8×12	220	6	1.1	38	5.1	270	16	560	240	
							380	4								
MONA200A	1:1	450-0.4C	450	0.4	200	5×Φ8×12	220	7	1.2	38	5.1	300	16	560	240	
							380	5								
MONA200A	1:1	320-0.4D	320	0.4	240	4×Φ8×12	220	6	0.9	32	4.3	260	16	560	240	
							380	4								
MONA200A	1:1	400-0.4D	400	0.4	240	5×Φ8×12	220	7	1.1	32	4.3	320	16	560	240	
							380	5								

注 Remark:

1、本机用于无机房。The machine is used for machine roomless.

2、样本切口角为推荐值，可根据实际工况要求选择切口角度。The above is recommended value of cut angle, it's optional according to practical condition.

电源电压	Voltage	220V / 380V
悬挂比	Roping	2:1 / 1:1
绕绳方式	Wrap	单绕(Single)
额定载重	Elv. Load	(320 ~ 450)kg
电梯速度	Elv. Speed	0.4m/s
曳引轮节径	Sheave Diam	200mm / 240mm
工作制	Duty	S5 - 40%ED
起动次数	Starts Per Hour	180st/h
最大轴静载	Max. Static Load	2500kg
自重	Weight	160kg
制动器	Brake	DC110V 2.5A
防护等级	IP Code	IP41
绝缘等级	Ins. Class	F

# MONA320

Permanent Magnet Synchronous Gearless Traction Machine  
永磁同步无齿轮曳引机

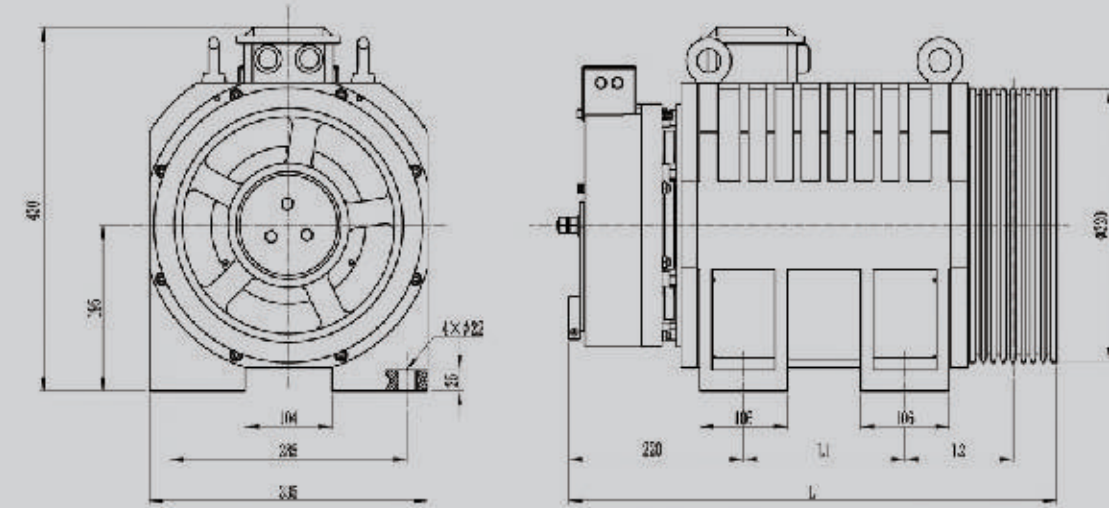
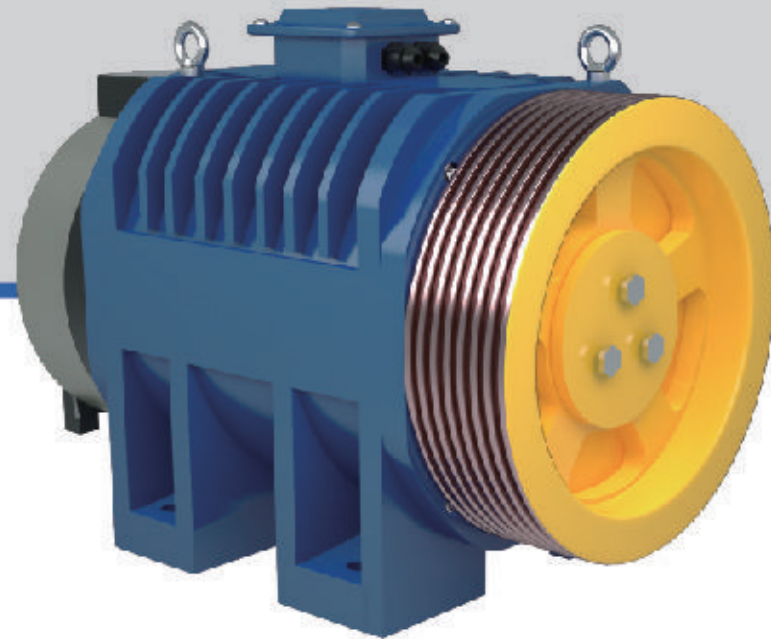

安装尺寸图  
DIMENSIONS

MONA320

## 规格表/SPEC.SHEET

型号	规格	额定载重	额定梯速	曳引轮节径	曳引轮槽槽	额定电流	额定功率	额定转速	额定频率	额定转矩	电机极数	L	L1	L2	推荐切口角
Type	Spec	Elv Load	Elv Speed	Sheave Dia	Sheave Groove	Current	Power	Speed	Freq	Torque	Poles	mm	mm	mm	Undercut Angle
		kg	m/s	mm		A	kW	r/min	Hz	N·m					°
MONA320	630-0.5	630	0.5	320	5×Φ8×12	7	2.1	60	12.0	340	24	550	154	124.5	90
MONA320	630-0.63	630	0.63	320	5×Φ8×12	7	2.7	75	15.0	340	24	550	154	124.5	
MONA320	630-1.0	630	1.0	320	5×Φ8×12	10	4.2	119	23.8	340	24	550	154	124.5	
MONA320	630-1.5	630	1.5	320	5×Φ8×12	16	6.4	179	35.8	340	24	550	154	124.5	
MONA320	630-1.6	630	1.6	320	5×Φ8×12	16	6.8	191	38.2	340	24	550	154	124.5	
MONA320	630-1.75	630	1.75	320	5×Φ8×12	16	7.4	209	41.8	340	24	550	154	124.5	
MONA320	800-0.5	800	0.5	320	6×Φ8×12	9	2.7	60	12.0	430	24	550	154	124.5	90
MONA320	800-0.63	800	0.63	320	6×Φ8×12	9	3.4	75	15.0	430	24	550	154	124.5	
MONA320	800-1.0	800	1.0	320	6×Φ8×12	13	5.4	119	23.8	430	24	550	154	124.5	
MONA320	800-1.5	800	1.5	320	6×Φ8×12	20	8.1	179	35.8	430	24	550	154	124.5	
MONA320	800-1.6	800	1.6	320	6×Φ8×12	20	8.6	191	38.2	430	24	550	154	124.5	
MONA320	800-1.75	800	1.75	320	6×Φ8×12	20	9.4	209	41.8	430	24	550	154	124.5	
MONA320	1000-0.5	1000	0.5	320	7×Φ8×12	11	3.4	60	12.0	540	24	590	194	124.5	85
MONA320	1000-0.63	1000	0.63	320	7×Φ8×12	11	4.2	75	15.0	540	24	590	194	124.5	
MONA320	1000-1.0	1000	1.0	320	7×Φ8×12	16	6.7	119	23.8	540	24	590	194	124.5	
MONA320	1000-1.5	1000	1.5	320	7×Φ8×12	25	10.1	179	35.8	540	24	590	194	124.5	
MONA320	1000-1.6	1000	1.6	320	7×Φ8×12	25	10.8	191	38.2	540	24	590	194	124.5	
MONA320	1000-1.75	1000	1.75	320	7×Φ8×12	25	11.8	209	41.8	540	24	590	194	124.5	
MONA320	1150-0.5	1150	0.5	320	8×Φ8×12	12	4	60	12.0	630	24	602	194	130.5	85
MONA320	1150-0.63	1150	0.63	320	8×Φ8×12	12	4.9	75	15.0	630	24	602	194	130.5	
MONA320	1150-1.0	1150	1.0	320	8×Φ8×12	18	7.9	119	23.8	630	24	602	194	130.5	
MONA320	1150-1.5	1150	1.5	320	8×Φ8×12	30	11.8	179	35.8	630	24	602	194	130.5	
MONA320	1150-1.6	1150	1.6	320	8×Φ8×12	30	12.6	191	38.2	630	24	602	194	130.5	
MONA320	1150-1.75	1150	1.75	320	8×Φ8×12	30	13.8	209	41.8	630	24	602	194	130.5	

注 Remark:

1、本机型用于无机房。The machine is used for machine roomless.

2、样本切口角为推荐值，可根据实际工况要求选择切口角度。

The above is recommended value of cut angle, it's optional according to practical condition.

电源电压	Voltage	380V
悬挂比	Roping	2:1
绕绳方式	Wrap	单绕(Single)
额定载重	Elv. Load	(630 ~ 1150)kg
电梯速度	Elv. Speed	(0.5 ~ 1.75)m/s
曳引轮节径	Sheave Diam	320mm
工作制	Duty	S5 - 40%ED
起动次数	Starts Per Hour	240st/h
最大轴静载	Max. Static Load	3500kg
自重	Weight	300kg
制动器	Brake	DC110V 2.6A
防护等级	IP Code	IP41
绝缘等级	Ins. Class	F

# MONA320A

Permanent Magnet Synchronous Gearless Traction Machine  
永磁同步无齿轮曳引机

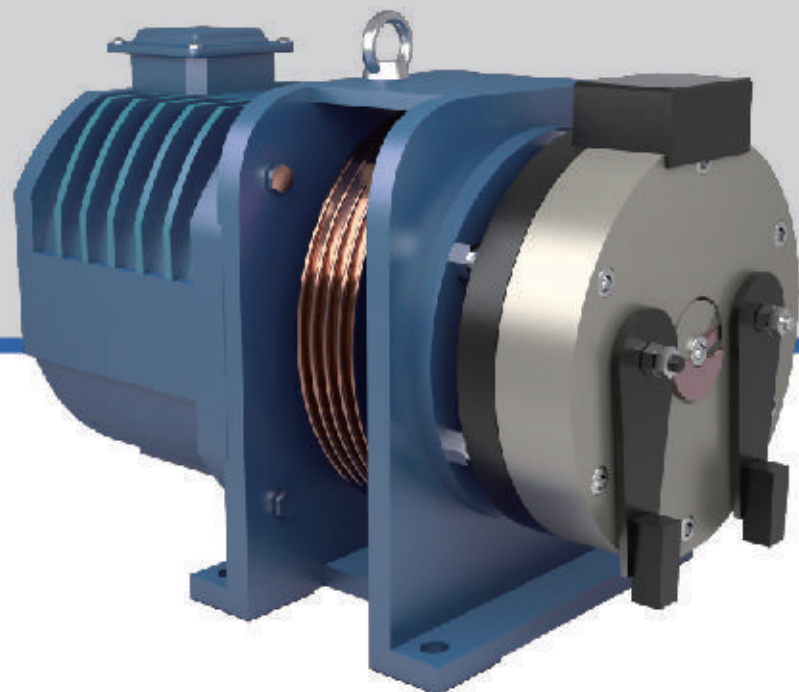

安装尺寸图  
DIMENSIONS

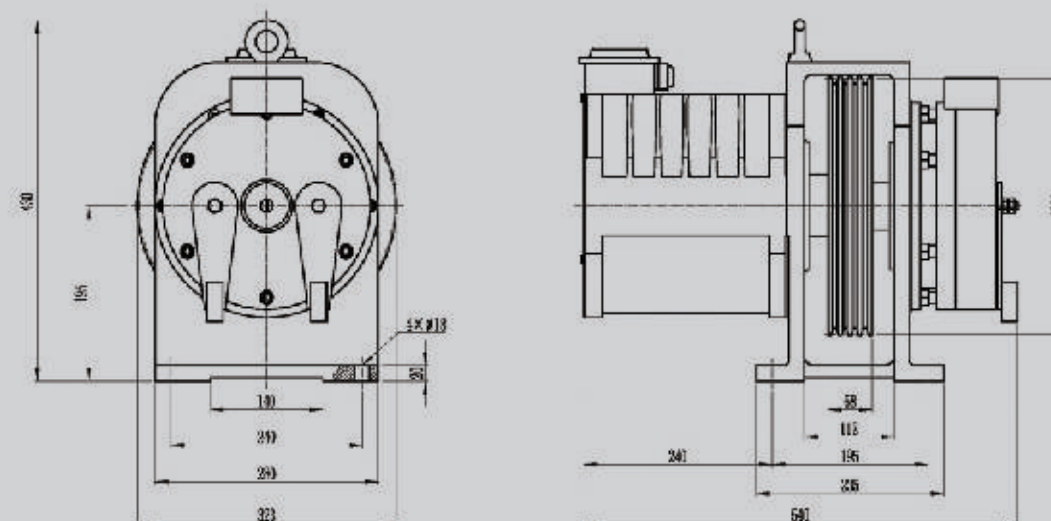

MONA320A

## 规格表/SPEC.SHEET

型号	规格	额定载重	额定梯速	曳引轮节径	曳引轮绳槽	电源电压	额定电流	额定功率	额定转速	额定频率	额定转矩	电机极数	推荐切口角
Type	Spec	Elv Load	Elv Speed	Sheave Dia	Sheave Groove	Voltage	Current	Power	Speed	Freq	Torque	Poles	Undercut Angle
		kg	m/s	mm		V	A	kW	r/min	Hz	N·m		°
MONA320A	320-0.5A	320	0.5	320	3×Φ8×12	220	6	1.1	60	12.0	170	24	90
						380	4						
MONA320A	320-0.63A	320	0.63	320	3×Φ8×12	220	6	1.3	75	15.0	170	24	
						380	4						
MONA320A	320-1.0A	320	1.0	320	3×Φ8×12	220	9	2.1	119	23.8	170	24	
						380	6						
MONA320A	400-0.5A	400	0.5	320	4×Φ8×12	220	8	1.4	60	12.0	220	24	
						380	5						
MONA320A	400-0.63A	400	0.63	320	4×Φ8×12	220	8	1.7	75	15.0	220	24	
						380	5						
MONA320A	400-1.0A	400	1.0	320	4×Φ8×12	220	11	2.7	119	23.8	220	24	
						380	8						
MONA320A	450-0.5A	450	0.5	320	4×Φ8×12	220	9	1.5	60	12.0	240	24	
						380	6						
MONA320A	450-0.63A	450	0.63	320	4×Φ8×12	220	9	1.9	75	15.0	240	24	
						380	6						
MONA320A	450-1.0A	450	1.0	320	4×Φ8×12	220	12	3	119	23.8	240	24	
						380	9						

电源电压	Voltage	220V/380V
悬挂比	Roping	2:1
绕绳方式	Wrap	单绕(Single)
额定载重	Elv. Load	(320 ~ 450)kg
电梯速度	Elv. Speed	(0.5 ~ 1.0)m/s
曳引轮节径	Sheave Diam	320mm
工作制	Duty	S5 - 40%ED
起动次数	Starts Per Hour	240st/h
最大轴静载	Max. Static Load	2500kg
自重	Weight	200kg
制动器	Brake	DC110V 2.5A
防护等级	IP Code	IP41
绝缘等级	Ins. Class	F

注 Remark:

- 1、本机用于无机房。The machine is used for machine roomless.
- 2、样本切口角为推荐值，可根据实际工况要求选择切口角度。The above is recommended value of cut angle, it's optional according to practical condition.

# MONA320B

Permanent Magnet Synchronous Gearless Traction Machine  
永磁同步无齿轮曳引机

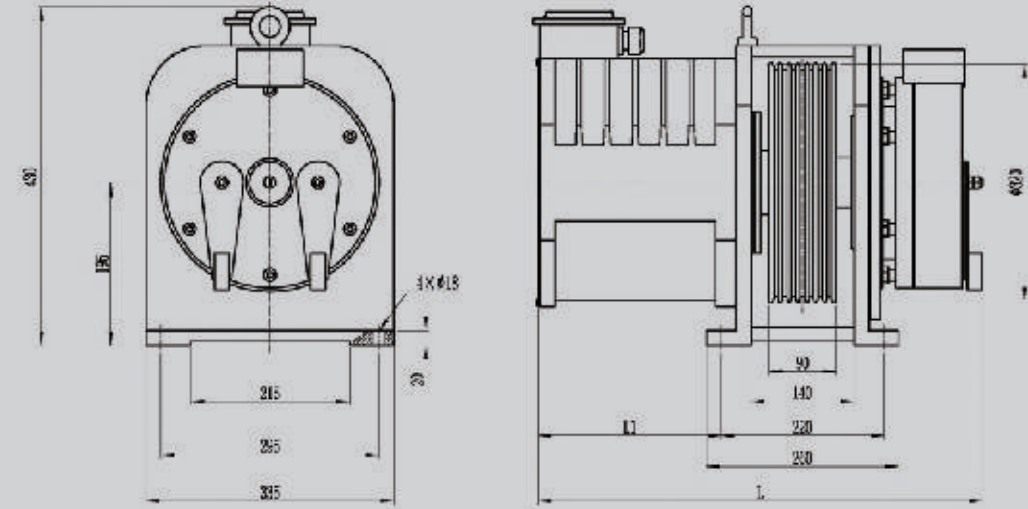
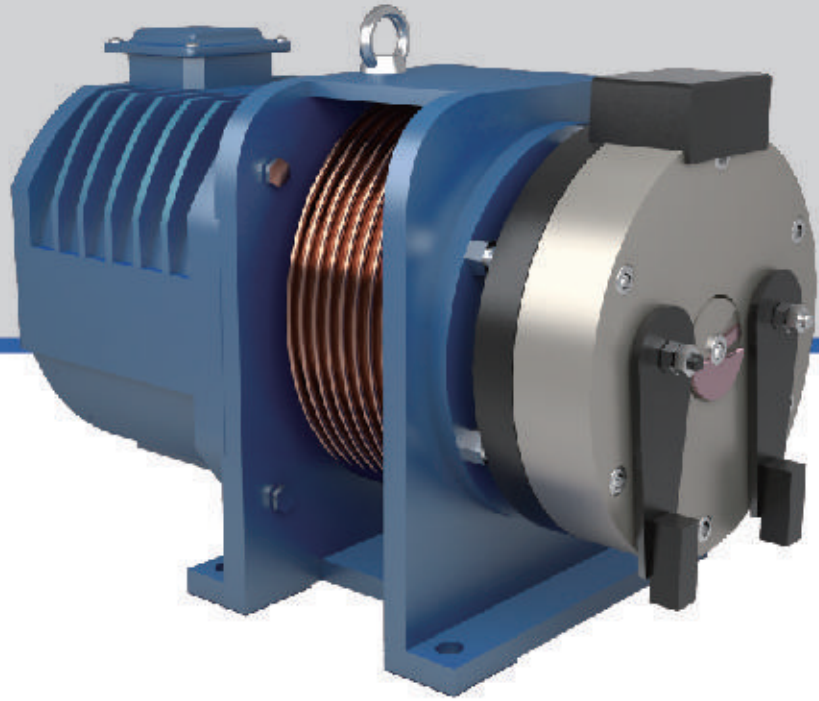

安装尺寸图  
DIMENSIONS

MONA320B

## 规格表/SPEC.SHEET

型号	规格	额定载重	额定梯速	曳引轮节径	曳引轮绳槽	额定电流	额定功率	额定转速	额定频率	额定转矩	电机极数	L	L1	推荐切口角
Type	Spec	Elv Load	Elv Speed	Sheave Dia	Sheave Groove	Current	Power	Speed	Freq	Torque	Poles			UndercutAngle
		kg	m/s	mm		A	kW	r/min	Hz	N·m		mm	mm	°
MONA320B	630-0.5B	630	0.5	320	5×Φ8×12	7	2.1	60	12.0	340	24	605	250	90
MONA320B	630-0.63B	630	0.63	320	5×Φ8×12	7	2.7	75	15.0	340	24	605	250	
MONA320B	630-1.0B	630	1.0	320	5×Φ8×12	10	4.2	119	23.8	340	24	605	250	
MONA320B	630-1.5B	630	1.5	320	5×Φ8×12	16	6.4	179	35.8	340	24	605	250	
MONA320B	630-1.6B	630	1.6	320	5×Φ8×12	16	6.8	191	38.2	340	24	605	250	
MONA320B	630-1.75B	630	1.75	320	5×Φ8×12	16	7.4	209	41.8	340	24	605	250	
MONA320B	800-0.5B	800	0.5	320	6×Φ8×12	9	2.7	60	12.0	430	24	605	250	90
MONA320B	800-0.63B	800	0.63	320	6×Φ8×12	9	3.4	75	15.0	430	24	605	250	
MONA320B	800-1.0B	800	1.0	320	6×Φ8×12	13	5.4	119	23.8	430	24	605	250	
MONA320B	800-1.5B	800	1.5	320	6×Φ8×12	20	8.1	179	35.8	430	24	605	250	
MONA320B	800-1.6B	800	1.6	320	6×Φ8×12	20	8.6	191	38.2	430	24	605	250	
MONA320B	800-1.75B	800	1.75	320	6×Φ8×12	20	9.4	209	41.8	430	24	605	250	
MONA320B	1000-0.5B	1000	0.5	320	7×Φ8×12	11	3.4	60	12.0	540	24	645	290	85
MONA320B	1000-0.63B	1000	0.63	320	7×Φ8×12	11	4.2	75	15.0	540	24	645	290	
MONA320B	1000-1.0B	1000	1.0	320	7×Φ8×12	16	6.7	119	23.8	540	24	645	290	
MONA320B	1000-1.5B	1000	1.5	320	7×Φ8×12	25	10.1	179	35.8	540	24	645	290	
MONA320B	1000-1.6B	1000	1.6	320	7×Φ8×12	25	10.8	191	38.2	540	24	645	290	
MONA320B	1000-1.75B	1000	1.75	320	7×Φ8×12	25	11.8	209	41.8	540	24	645	290	

电源电压	Voltage	380V
悬挂比	Roping	2:1
绕绳方式	Wrap	单绕(Single)
额定载重	Elv. Load	(630 ~ 1000)kg
电梯速度	Elv. Speed	(0.5 ~ 1.75)m/s
曳引轮节径	Sheave Diam	320mm
工作制	Duty	S5 - 40%ED
启动次数	Starts Per Hour	240st/h
最大轴静载	Max. Static Load	3000kg
自重	Weight	290kg
制动器	Brake	DC110V 2.6A
防护等级	IP Code	IP41
绝缘等级	Ins. Class	F

注 Remark:

1、本机型用于无机房。The machine is used for machine roomless.

2、样本切口角为推荐值,可根据实际工况要求选择切口角度。The above is recommended value of cut angle,it's optional according to practical condition.

# MONA400

Permanent Magnet Synchronous Gearless Traction Machine  
永磁同步无齿轮曳引机

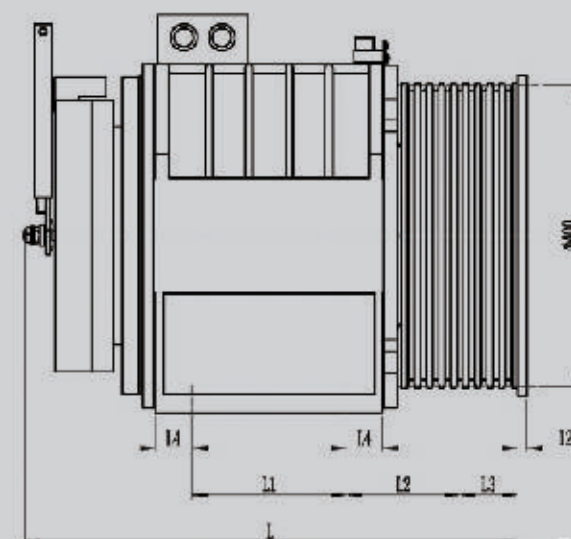
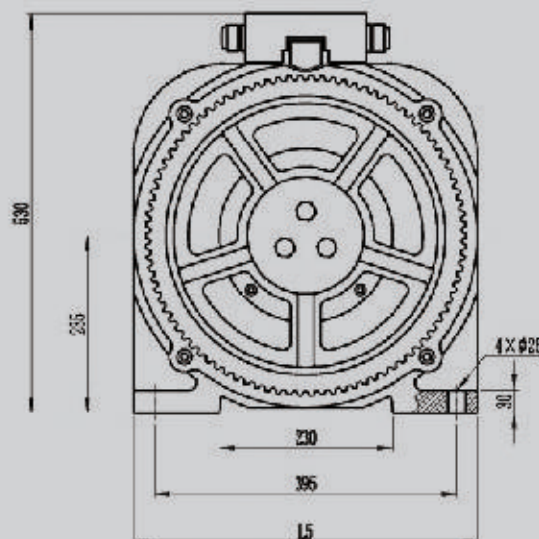
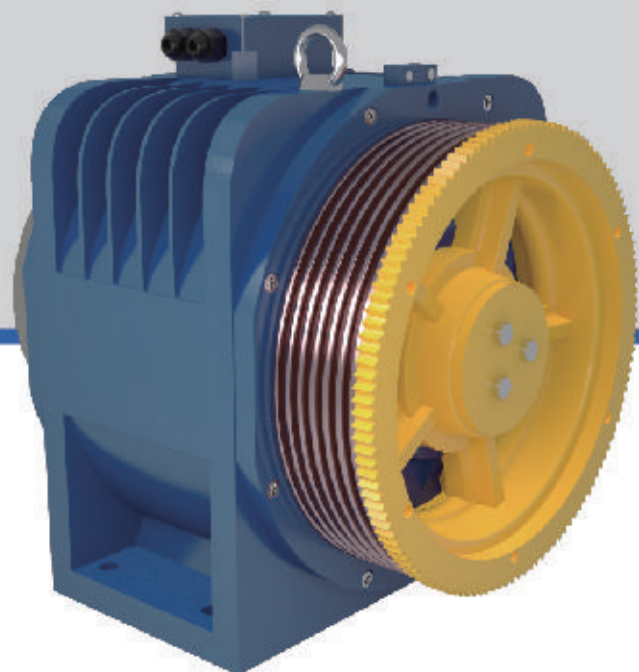

安装尺寸图  
DIMENSIONS

MONA400

## 规格表/SPEC.SHEET

型号	规格	额定载重	额定速度	曳引轮节径	曳引轮槽宽	额定电流	额定功率	额定转速	额定频率	额定转矩	电机极数	L	L1	L2	L3	L4	L5	推荐切口角
Type	Spec	Elv Load	Elv Speed	Sheave Dia	Sheave Groove	Current	Power	Speed	Freq	Torque	Poles	mm	mm	mm	mm	mm	mm	Undercut Angle
		kg	m/s	mm		A	kW	r/min	Hz	N·m		mm	mm	mm	mm	mm	mm	°
MONA400	800-1.0	800	1.0	400	5×Φ10×15	13	5.4	95	25.3	540	32	480	105	108.5	45	38	455	
MONA400	800-1.5	800	1.5	400	5×Φ10×15	20	8.1	143	38.1	540	32	480	105	108.5	45	38	455	
MONA400	800-1.6	800	1.6	400	5×Φ10×15	20	8.7	153	40.8	540	32	480	105	108.5	45	38	455	
MONA400	800-1.75	800	1.75	400	5×Φ10×15	20	9.4	167	44.5	540	32	480	105	108.5	45	38	455	
MONA400	800-2.0	800	2.0	400	5×Φ10×15	23	10.8	191	50.9	540	32	480	105	108.5	45	38	455	
MONA400	800-2.5	800	2.5	400	5×Φ10×15	29	13.5	239	63.7	540	32	480	105	108.5	45	38	455	
MONA400	1000-1.0	1000	1.0	400	5×Φ10×15	16	6.7	95	25.3	670	32	505	130	108.5	45	38	455	
MONA400	1000-1.5	1000	1.5	400	5×Φ10×15	25	10.0	143	38.1	670	32	505	130	108.5	45	38	455	
MONA400	1000-1.6	1000	1.6	400	5×Φ10×15	25	10.7	153	40.8	670	32	505	130	108.5	45	38	455	
MONA400	1000-1.75	1000	1.75	400	5×Φ10×15	25	11.7	167	44.5	670	32	505	130	108.5	45	38	455	
MONA400	1000-2.0	1000	2.0	400	5×Φ10×15	29	13.4	191	50.9	670	32	505	130	108.5	45	38	455	
MONA400	1000-2.5	1000	2.5	400	6×Φ10×15	36	16.8	239	63.7	670	32	521	130	116.5	53	38	455	
MONA400	1150-1.0	1150	1.0	400	5×Φ10×15	18	7.8	95	25.3	780	32	509	148	108.5	45	38	455	
MONA400	1150-1.5	1150	1.5	400	6×Φ10×15	29	11.7	143	38.1	780	32	525	148	116.5	53	38	455	
MONA400	1150-1.6	1150	1.6	400	6×Φ10×15	29	12.5	153	40.8	780	32	525	148	116.5	53	38	455	
MONA400	1150-1.75	1150	1.75	400	6×Φ10×15	29	13.6	167	44.5	780	32	525	148	116.5	53	38	455	
MONA400	1150-2.0	1150	2.0	400	6×Φ10×15	33	15.6	191	50.9	780	32	525	148	116.5	53	38	455	
MONA400	1150-2.5	1150	2.5	400	6×Φ10×15	43	19.5	239	63.7	780	32	525	148	116.5	53	38	455	
MONA400	1350-1.0	1350	1.0	400	7×Φ10×15	21	9.2	95	25.3	920	32	685	205	150.5	77	48	475	
MONA400	1350-1.5	1350	1.5	400	7×Φ10×15	34	13.8	143	38.1	920	32	685	205	150.5	77	48	475	
MONA400	1350-1.6	1350	1.6	400	7×Φ10×15	34	14.7	153	40.8	920	32	685	205	150.5	77	48	475	
MONA400	1350-1.75	1350	1.75	400	7×Φ10×15	34	16.1	167	44.5	920	32	685	205	150.5	77	48	475	
MONA400	1350-2.0	1350	2.0	400	7×Φ10×15	39	18.4	191	50.9	920	32	685	205	150.5	77	48	475	
MONA400	1350-2.5	1350	2.5	400	7×Φ10×15	50	23	239	63.7	920	32	685	205	150.5	77	48	475	
MONA400	1600-1.0	1600	1.0	400	7×Φ10×15	25	11.0	95	25.3	1110	32	685	205	150.5	77	48	475	
MONA400	1600-1.5	1600	1.5	400	8×Φ10×15	41	16.6	143	38.1	1110	32	685	205	150.5	77	48	475	
MONA400	1600-1.6	1600	1.6	400	8×Φ10×15	41	17.8	153	40.8	1110	32	685	205	150.5	77	48	475	
MONA400	1600-1.75	1600	1.75	400	8×Φ10×15	41	19.4	167	44.5	1110	32	685	205	150.5	77	48	475	
MONA400	1600-2.0	1600	2.0	400	8×Φ10×15	47	22.2	191	50.9	1110	32	685	205	150.5	77	48	475	
MONA400	1600-2.5	1600	2.5	400	8×Φ10×15	60	27.8	239	63.7	1110	32	685	205	150.5	77	48	475	

注 Remark:

- 1、本机型亦可用于无机房。The machine can also be used for machine roomless.
- 2、样本切口角为推荐值，可根据实际工况要求选择切口角度。The above is recommended value of cut angle, it's optional according to practical condition.

电源电压	Voltage	380V
悬挂比	Roping	2:1
绕绳方式	Wrap	单绕(Single)
额定载重	Elv. Load	(800 ~ 1600)kg
电梯速度	Elv. Speed	(0.5 ~ 2.5)m/s
曳引轮节径	Sheave Diam	400mm
工作制	Duty	S5 - 40%ED
起动次数	Starts Per Hour	240st/h
最大轴静载	Max. Static Load	5500kg
自重	Weight	480kg
制动器	Brake	DC110V 2×1.8A
防护等级	IP Code	IP41
绝缘等级	Ins. Class	F

# MONA450

Permanent Magnet Synchronous Gearless Traction Machine

永磁同步无齿轮曳引机

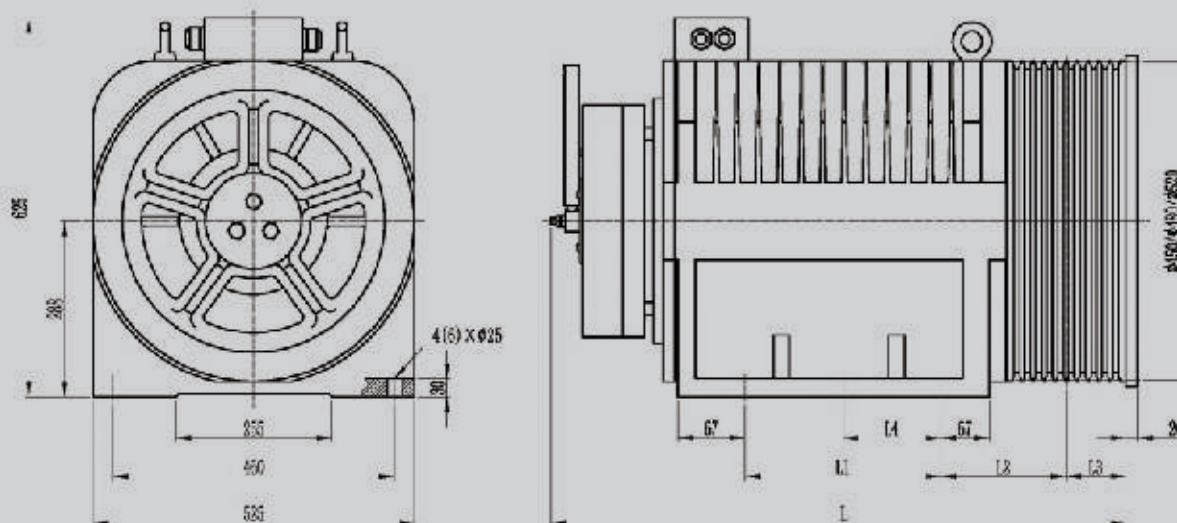

安装尺寸图  
DIMENSIONS

MONA450

规格表/SPEC.SHEET

型号 Type	规格 Spec	额定载重 Elv. Load kg	额定速度 Elv. Speed m/s	曳引轮节径 Sheave Dia mm	曳引轮绳槽 Sheave Groove	额定电流 Current A	额定功率 Power kW	额定转速 Speed r/min	额定频率 Freq Hz	额定转矩 Torque N·m	电机极数 Poles	L	L1	L2	L3	L4	推荐切口角 Undercut Angle °
MONA450	1350-0.5	1350	0.5	450	7×Φ10×15	14	4.5	42	11.2	1030	32	630	144	160	65	/	
MONA450	1350-0.63	1350	0.63	450	7×Φ10×15	14	5.7	53	14.1	1030	32	630	144	160	65	/	
MONA450	1350-1.0	1350	1.0	450	7×Φ10×15	21	9.2	85	22.7	1030	32	630	144	160	65	/	
MONA450	1350-1.5	1350	1.5	450	7×Φ10×15	34	13.7	127	33.9	1030	32	630	144	160	65	/	
MONA450	1350-1.6	1350	1.6	450	7×Φ10×15	34	14.7	136	36.3	1030	32	630	144	160	65	/	
MONA450	1350-1.75	1350	1.75	450	7×Φ10×15	34	16.1	149	39.7	1030	32	630	144	160	65	/	
MONA450	1350-2.0	1350	2.0	450	7×Φ10×15	40	18.3	170	45.3	1030	32	630	144	160	65	/	
MONA450	1350-2.5	1350	2.5	450	7×Φ10×15	48	22.9	212	56.5	1030	32	630	144	160	65	/	
MONA450	1350-3.0	1350	3.0	450	7×Φ10×15	56	27.5	255	68.0	1030	32	630	144	160	65	/	
MONA450	1600-0.5	1600	0.5	450	7×Φ10×15	17	5.5	42	11.2	1250	32	630	144	160	65	/	
MONA450	1600-0.63	1600	0.63	450	7×Φ10×15	17	6.9	53	14.1	1250	32	630	144	160	65	/	95
MONA450	1600-1.0	1600	1.0	450	7×Φ10×15	25	11.1	85	22.7	1250	32	630	144	160	65	/	
MONA450	1600-1.5	1600	1.5	450	8×Φ10×15	41	16.6	127	33.9	1250	32	630	144	160	65	/	
MONA450	1600-1.6	1600	1.6	450	8×Φ10×15	41	17.8	136	36.3	1250	32	630	144	160	65	/	
MONA450	1600-1.75	1600	1.75	450	8×Φ10×15	41	19.5	149	39.7	1250	32	630	144	160	65	/	
MONA450	1600-2.0	1600	2.0	450	8×Φ10×15	48	22.3	170	45.3	1250	32	630	144	160	65	/	
MONA450	1600-2.5	1600	2.5	450	8×Φ10×15	58	27.7	212	56.5	1250	32	630	144	160	65	/	
MONA450	1600-3.0	1600	3.0	450	8×Φ10×15	68	33.4	255	68.0	1250	32	630	144	160	65	/	
MONA450	2000-0.5	2000	0.5	450	8×Φ10×15	21	6.8	42	11.2	1550	32	680	194	160	65	/	
MONA450	2000-0.63	2000	0.63	450	8×Φ10×15	21	8.6	53	14.1	1550	32	680	194	160	65	/	
MONA450	2000-1.0	2000	1.0	450	8×Φ10×15	31	13.8	85	22.7	1550	32	680	194	160	65	/	
MONA450	2000-1.5	2000	1.5	450	9×Φ10×15	49	20.6	127	33.9	1550	32	704	194	172	77	/	
MONA450	2000-1.6	2000	1.6	450	9×Φ10×15	49	22.1	136	36.3	1550	32	704	194	172	77	/	
MONA450	2000-1.75	2000	1.75	450	9×Φ10×15	49	24.2	149	39.7	1550	32	704	194	172	77	/	
MONA450	2000-2.0	2000	2.0	450	9×Φ10×15	56	27.6	170	45.3	1550	32	704	194	172	77	/	
MONA450	2000-2.5	2000	2.5	450	9×Φ10×15	71	34.4	212	56.5	1550	32	704	194	172	77	/	
MONA450	2500-0.5	2500	0.5	480	8×Φ12×17	27	8.4	40	10.7	2000	32	765	254	180	85	127	
MONA450	2500-0.63	2500	0.63	480	8×Φ12×17	27	10.5	50	13.3	2000	32	765	254	180	85	127	
MONA450	2500-1.0	2500	1.0	480	8×Φ12×17	41	16.8	80	21.3	2000	32	765	254	180	85	127	
MONA450	2500-1.5	2500	1.5	480	8×Φ12×17	68	24.9	119	31.7	2000	32	765	254	180	85	127	
MONA450	2500-1.6	2500	1.6	480	8×Φ12×17	68	26.6	127	33.9	2000	32	765	254	180	85	127	
MONA450	2500-1.75	2500	1.75	480	8×Φ12×17	68	29.1	139	37.1	2000	32	765	254	180	85	127	
MONA450	2500-2.0	2500	2.0	520	7×Φ13×18	69	34.5	147	39.2	2240	32	941	370	188	90	185	
MONA450	2500-2.5	2500	2.5	520	7×Φ13×18	87	43.2	184	49.1	2240	32	941	370	188	90	185	
MONA450	3000-0.5	3000	0.5	520	8×Φ13×18	31	10.1	37	9.9	2600	32	941	370	188	90	185	
MONA450	3000-0.63	3000	0.63	520	8×Φ13×18	31	12.5	46	12.3	2600	32	941	370	188	90	185	
MONA450	3000-1.0	3000	1.0	520	8×Φ13×18	45	19.9	73	19.5	2600	32	941	370	188	90	185	
MONA450	3000-1.5	3000	1.5	520	8×Φ13×18	75	29.9	110	29.3	2600	32	941	370	188	90	185	
MONA450	3000-1.6	3000	1.6	520	8×Φ13×18	75	32.1	118	31.5	2600	32	941	370	188	90	185	
MONA450	3000-1.75	3000	1.75	520	8×Φ13×18	75	35.1	129	34.4	2600	32	941	370	188	90	185	

注 Remark:

- 1、本机亦可用于无机房。The machine can also be used for machine roomless.
- 2、样本切口角为推荐值，可根据实际工况要求选择切口角度。The above is recommended value of cut angle, it's optional according to practical condition.

电源电压	Voltage	380V
悬挂比	Roping	2:1
绕绳方式	Wrap	单绕(Single)
额定载重	Elv. Load	(1350 ~ 3000)kg
电梯速度	Elv. Speed	(0.5 ~ 3.0)m/s
曳引轮节径	Sheave Diam	450mm/480mm/520mm
工作制	Duty	S5 - 40%ED
起动次数	Starts Per Hour	240st/h
最大轴静载	Max. Static Load	12000kg
自重	Weight	900kg
制动器	Brake	DC110V 2×2.5A
防护等级	IP Code	IP41
绝缘等级	Ins. Class	F

# MGD87

Permanent Magnet Synchronous Gearless Traction Machine-Belt Type  
永磁同步无齿轮钢带曳引机

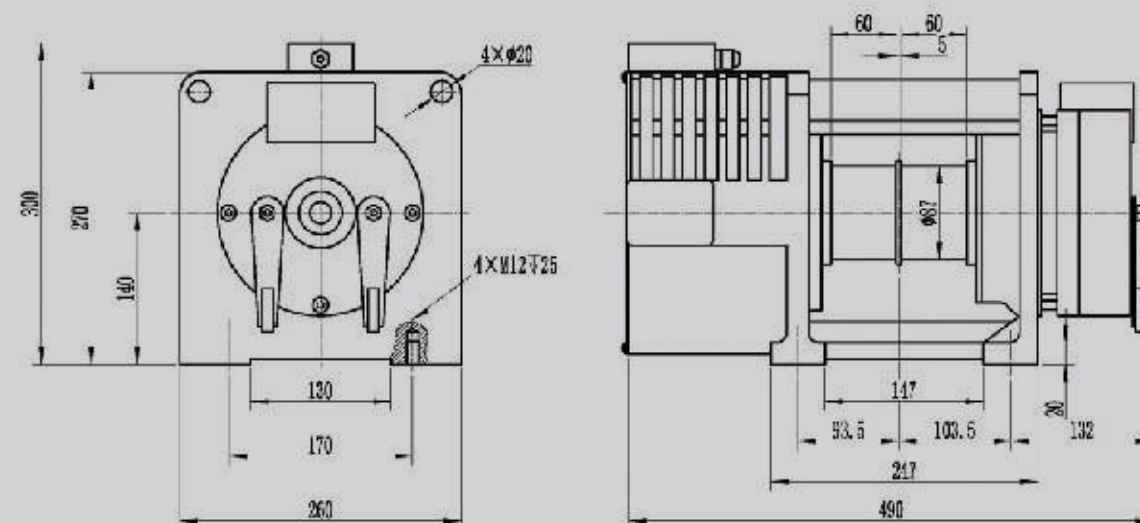

安装尺寸图  
DIMENSIONS

MGD87

## 规格表/SPEC.SHEET

型号	规格	额定载重	额定梯速	曳引轮直径	曳引轮钢带槽	电源电压	额定电流	额定功率	额定转速	额定频率	额定转矩	电机极数
Type	Spec	Elv Load	Elv Speed	Sheave Dia	Sheave Groove	Voltage	Current	Power	Speed	Freq	Torque	Poles
		kg	m/s	mm		V	A	kW	r/min	Hz	N·m	
MGD87	320-0.4	320	0.4	87	2x60	220/380	4	1.0	176	23.5	55	16
MGD87	320-0.5	320	0.5	87	2x60	220	7	1.3	220	29.3	55	16
						380	4					
MGD87	320-0.63	320	0.63	87	2x60	220	7	1.6	277	36.9	55	16
						380	4					
MGD87	320-1.0	320	1.0	87	2x60	220	10	2.5	439	58.5	55	16
						380	7					
MGD87	400-0.4	400	0.4	87	2x60	220/380	5	1.2	176	23.5	65	16
MGD87	400-0.5	400	0.5	87	2x60	220	8	1.5	220	29.3	65	16
						380	5					
MGD87	400-0.63	400	0.63	87	2x60	220	8	1.9	277	36.9	65	16
						380	5					
MGD87	400-1.0	400	1.0	87	2x60	220	12	3.0	439	58.5	65	16
						380	8					
MGD87	450-0.4	450	0.4	87	2x60	220/380	6	1.4	176	23.5	75	16
MGD87	450-0.5	450	0.5	87	2x60	220	9	1.7	220	29.3	75	16
						380	6					
MGD87	450-0.63	450	0.63	87	2x60	220	9	2.2	277	36.9	75	16
						380	6					
MGD87	450-1.0	450	1.0	87	2x60	220	14	3.4	439	58.5	75	16
						380	9					

电源电压	Voltage	220V / 380V
悬挂比	Roping	2:1
绕绳方式	Wrap	单绕(Single)
额定载重	Elv. Load	(320 ~ 450)kg
电梯速度	Elv. Speed	(0.4 ~ 1.0)m/s
曳引轮节径	Sheave Diam	87mm
工作制	Duty	S5 - 40%ED
起动次数	Starts Per Hour	180st/h
最大轴静载	Max. Static Load	2000kg
自重	Weight	80kg
制动器	Brake	DC110V 1.8A
防护等级	IP Code	IP41
绝缘等级	Ins. Class	F

注 Remark:

1、本机型用于无机房。The machine is used for machine roomless.



# MGD100

Permanent Magnet Synchronous Gearless Traction Machine-Belt Type  
永磁同步无齿轮钢带曳引机

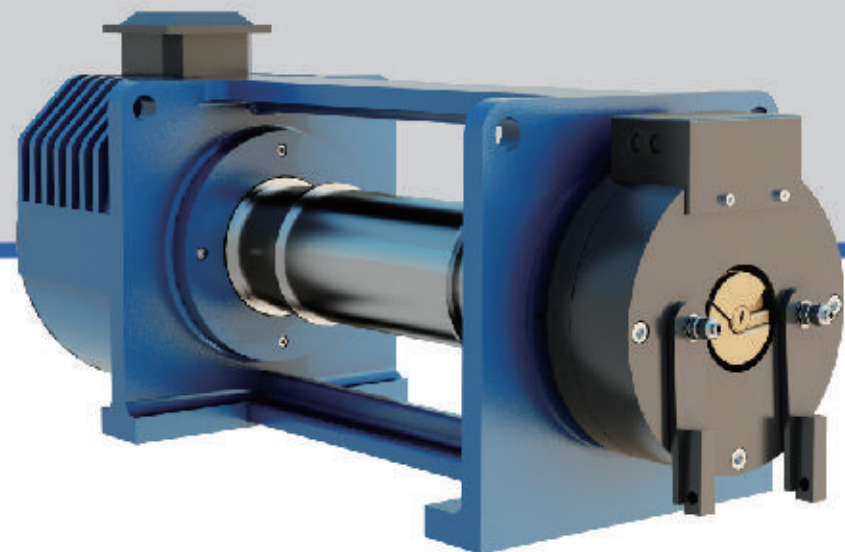

安装尺寸图  
DIMENSIONS

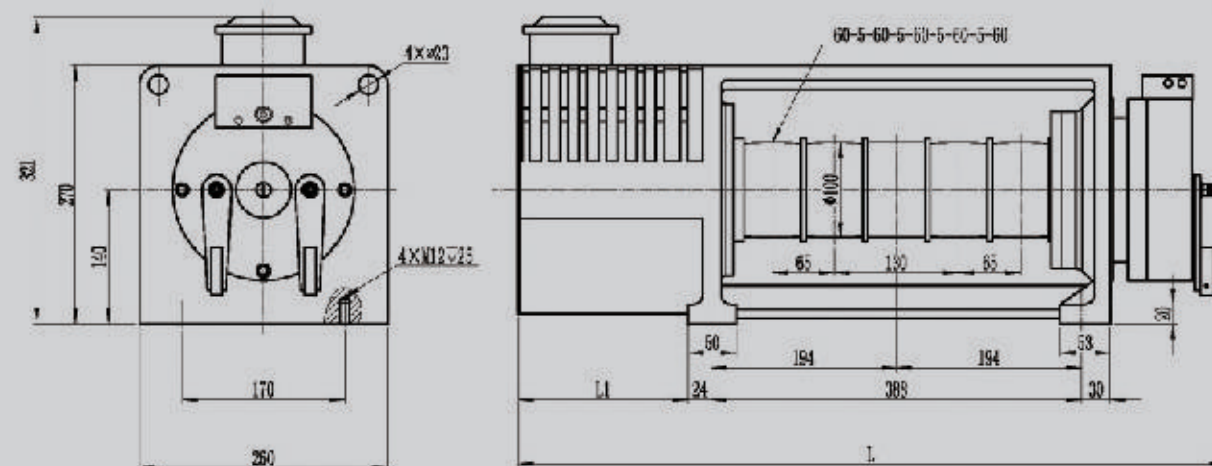

MGD100

## 规格表/SPEC.SHEET

型号	规格	额定载重	额定梯速	曳引轮直径	曳引轮钢带槽	电源电压	额定电流	额定功率	额定转速	额定频率	额定转矩	电机极数	L	L1
Type	Spec	Elv Load	Elv Speed	Sheave Dia	Sheave Groove	Voltage	Current	Power	Speed	Freq	Torque	Poles	mm	mm
		kg	m/s	mm		V	A	kW	r/min	Hz	N·m		mm	mm
MGD100	320-0.4	320	0.4	100	2x60	220/380	4	1.0	153	20.4	60	16	680.5	133
MGD100	320-0.5	320	0.5	100	2x60	220 380	7 4	1.2	191	25.5	60	16	680.5	133
MGD100	320-0.63	320	0.63	100	2x60	220 380	7 4	1.5	241	32.1	60	16	680.5	133
MGD100	320-1.0	320	1.0	100	2x60	220 380	9 6	2.4	382	50.9	60	16	680.5	133
MGD100	400-0.4	400	0.4	100	2x60	220/380	5	1.2	153	20.4	75	16	680.5	133
MGD100	400-0.5	400	0.5	100	2x60	220 380	8 5	1.5	191	25.5	75	16	680.5	133
MGD100	400-0.63	400	0.63	100	2x60	220 380	8 5	1.9	241	32.1	75	16	680.5	133
MGD100	400-1.0	400	1.0	100	2x60	220 380	12 8	3.0	382	50.9	75	16	680.5	133
MGD100	450-0.5	450	0.5	100	2x60	220 380	8 5	1.6	191	25.5	80	16	725.5	178
MGD100	450-0.63	450	0.63	100	2x60	220 380	8 5	2.0	241	32.1	80	16	725.5	178
MGD100	450-1.0	450	1.0	100	2x60	220 380	12 8	3.2	382	50.9	80	16	725.5	178
MGD100	630-0.5	630	0.5	100	3x60	220 380	11 7	2.2	191	25.5	110	16	725.5	178
MGD100	630-0.63	630	0.63	100	3x60	220 380	11 7	2.8	241	32.1	110	16	725.5	178
MGD100	630-1.0	630	1.0	100	3x60	220 380	16 11	4.4	382	50.9	110	16	725.5	178

注 Remark:

1、本机用于无机房。 The machine is used for machine roomless.

电源电压	Voltage	220V / 380V
悬挂比	Roping	2:1
绕绳方式	Wrap	单绕(Single)
额定载重	Elv. Load	(320 ~ 630)kg
电梯速度	Elv. Speed	(0.4 ~ 1.0)m/s
曳引轮节径	Sheave Diam	100mm
工作制	Duty	S5 - 40%ED
起动次数	Starts Per Hour	180st/h
最大轴静载	Max. Static Load	2500kg
自重	Weight	140kg
制动器	Brake	DC110V 1.8A
防护等级	IP Code	IP41
绝缘等级	Ins. Class	F

# MGD100A

Permanent Magnet Synchronous Gearless Traction Machine-Belt Type  
永磁同步无齿轮钢带曳引机

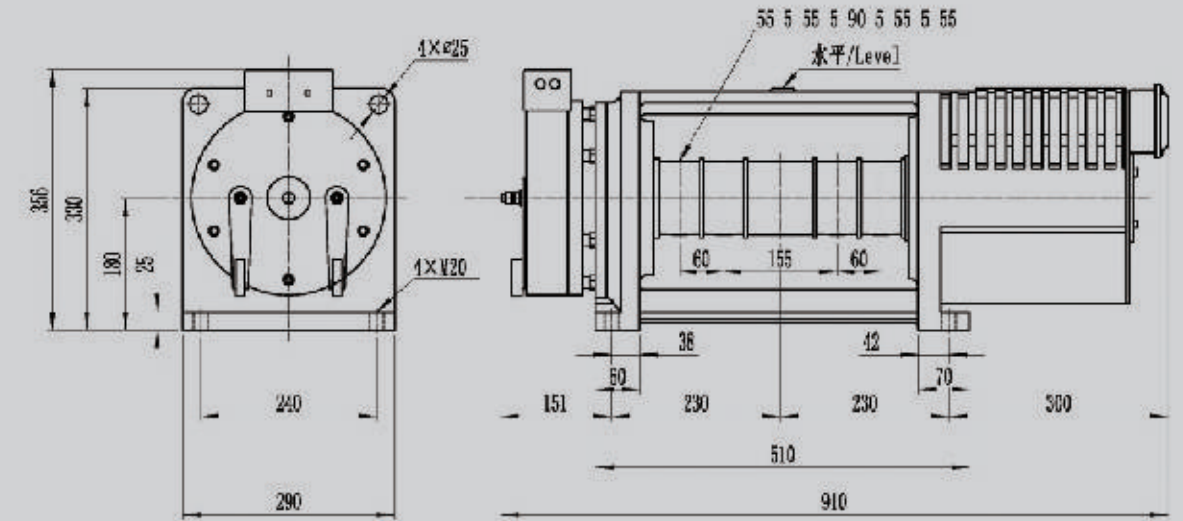
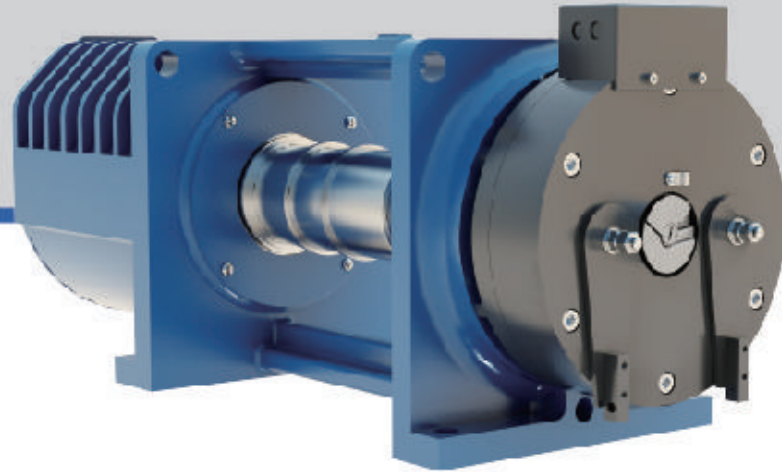

安装尺寸图  
DIMENSIONS

MGD100A

## 规格表/SPEC.SHEET

型号	规格	额定载重	额定梯速	曳引轮直径	曳引轮钢带槽	额定电流	额定功率	额定转速	额定频率	额定转矩	电机极数
Type	Spec	Elv Load	Elv Speed	Sheave Dia	Sheave Groove	Current	Power	Speed	Freq	Torque	Poles
		kg	m/s	mm		A	kW	r/min	Hz	N·m	
MGD100A	630-0.5	630	0.5	100	3x55	7	2.2	191	25.5	110	16
MGD100A	630-0.63	630	0.63	100	3x55	7	2.8	241	32.1	110	16
MGD100A	630-1.0	630	1.0	100	3x55	10	4.4	382	50.9	110	16
MGD100A	630-1.5	630	1.5	100	3x55	17	6.6	573	76.4	110	16
MGD100A	630-1.75	630	1.75	100	3x55	17	7.7	668	89.1	110	16
MGD100A	800-0.5	800	0.5	100	4x55	8	2.6	191	25.5	130	16
MGD100A	800-0.63	800	0.63	100	4x55	8	3.3	241	32.1	130	16
MGD100A	800-1.0	800	1.0	100	4x55	12	5.2	382	50.9	130	16
MGD100A	800-1.5	800	1.5	100	4x55	20	7.8	573	76.4	130	16
MGD100A	800-1.75	800	1.75	100	4x55	20	9.1	668	89.1	130	16
MGD100A	1000-0.5	1000	0.5	100	4x55	10	3.4	191	25.5	170	16
MGD100A	1000-0.63	1000	0.63	100	4x55	10	4.3	241	32.1	170	16
MGD100A	1000-1.0	1000	1.0	100	4x55	16	6.8	382	50.9	170	16
MGD100A	1000-1.5	1000	1.5	100	4x55	26	10.2	573	76.4	170	16
MGD100A	1000-1.75	1000	1.75	100	4x55	26	11.9	668	89.1	170	16
MGD100A	1050-0.5	1050	0.5	100	4x55	11	3.6	191	25.5	180	16
MGD100A	1050-0.63	1050	0.63	100	4x55	11	4.5	241	32.1	180	16
MGD100A	1050-1.0	1050	1.0	100	4x55	17	7.2	382	50.9	180	16
MGD100A	1050-1.5	1050	1.5	100	4x55	27	10.8	573	76.4	180	16
MGD100A	1050-1.75	1050	1.75	100	4x55	27	12.6	668	89.1	180	16

注 Remark:

1、本机用于无机房。The machine is used for machine roomless.

电源电压	Voltage	380V
悬挂比	Roping	2:1
绕绳方式	Wrap	单绕(Single)
额定载重	Elv. Load	(630 ~ 1050)kg
电梯速度	Elv. Speed	(0.5 ~ 1.75)m/s
曳引轮节径	Sheave Diam	100mm
工作制	Duty	S5 - 40%ED
起动次数	Starts Per Hour	240st/h
最大轴静载	Max. Static Load	3000kg
自重	Weight	210kg
制动器	Brake	DC110V 2.4A
防护等级	IP Code	IP41
绝缘等级	Ins. Class	F

# MGD120

Permanent Magnet Synchronous Gearless Traction Machine-Belt Type  
永磁同步无齿轮钢带曳引机

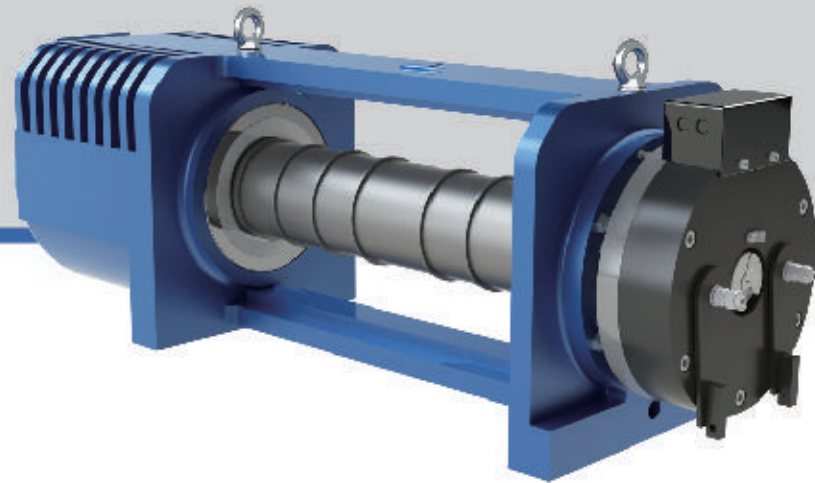

安装尺寸图  
DIMENSIONS

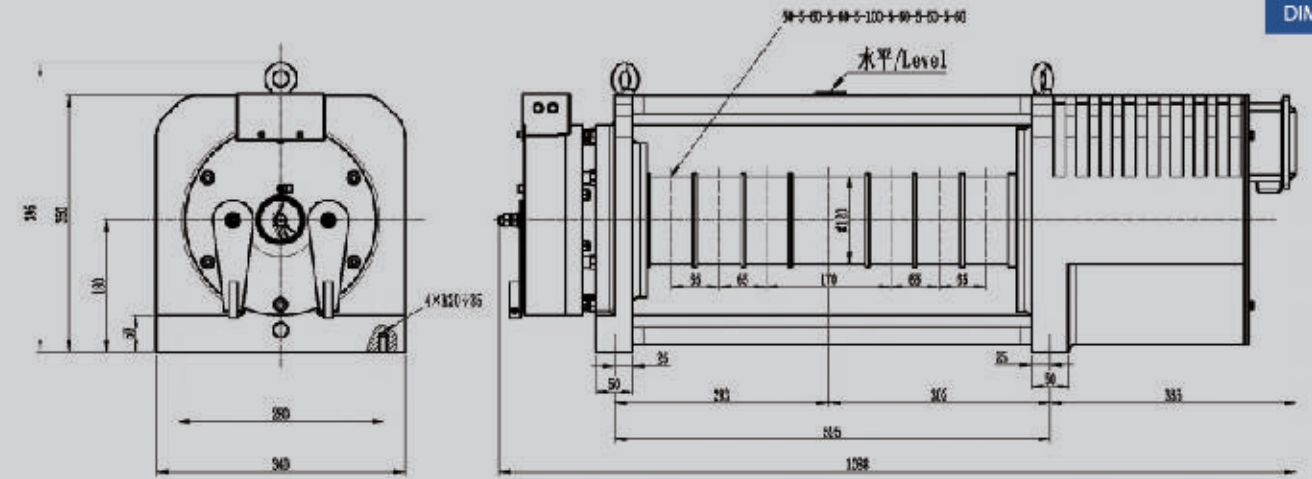

MGD120

## 规格表/SPEC.SHEET

型号	规格	额定载重	额定梯速	曳引轮直径	曳引轮钢带槽	额定电流	额定功率	额定转速	额定频率	额定转矩	电机极数
Type	Spec	Elv Load	Elv Speed	Sheave Dia	Sheave Groove	Current	Power	Speed	Freq	Torque	Poles
		kg	m/s	mm		A	kW	r/min	Hz	N·m	
MGD120	1150-1.0	1150	1.0	120	4×60	17	7.7	318	31.8	230	12
MGD120	1150-1.5	1150	1.5	120	4×60	24	11.5	477	47.7	230	12
MGD120	1150-1.75	1150	1.75	120	4×60	27	13.4	557	55.7	230	12
MGD120	1250-1.0	1250	1.0	120	6×60	18	8.3	318	31.8	250	12
MGD120	1250-1.5	1250	1.5	120	6×60	26	12.5	477	47.7	250	12
MGD120	1250-1.75	1250	1.75	120	6×60	30	14.6	557	55.7	250	12
MGD120	1350-1.0	1350	1.0	120	6×60	20	9.3	318	31.8	280	12
MGD120	1350-1.5	1350	1.5	120	6×60	29	14.0	477	47.7	280	12
MGD120	1350-1.75	1350	1.75	120	6×60	33	16.3	557	55.7	280	12
MGD120	1600-1.0	1600	1.0	120	6×60	24	11.0	318	31.8	330	12
MGD120	1600-1.5	1600	1.5	120	6×60	34	16.5	477	47.7	330	12
MGD120	1600-1.75	1600	1.75	120	6×60	39	19.2	557	55.7	330	12

电源电压	Voltage	380V
悬挂比	Roping	2:1
绕绳方式	Wrap	单绕(Single)
额定载重	Elv. Load	(1150 ~ 1600)kg
电梯速度	Elv. Speed	(1.0 ~ 1.75)m/s
曳引轮节径	Sheave Diam	120mm
工作制	Duty	S5 - 40%ED
起动次数	Starts Per Hour	240st/h
最大轴静载	Max. Static Load	5000kg
自重	Weight	260kg
制动器	Brake	DC110V 2.5A
防护等级	IP Code	IP41
绝缘等级	Ins. Class	F

注 Remark:

1、本机用于无机房。 The machine is used for machine roomless.

# MCB100

Permanent Magnet Synchronous Gearless Traction Machine  
永磁同步无齿轮曳引机

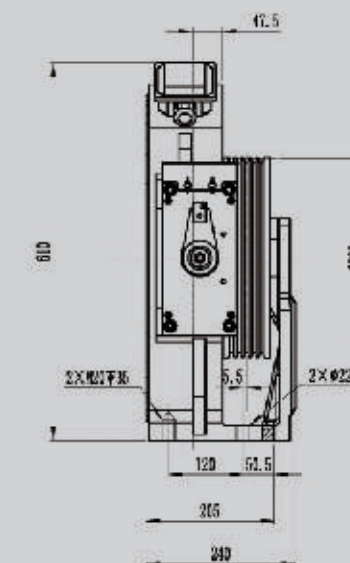
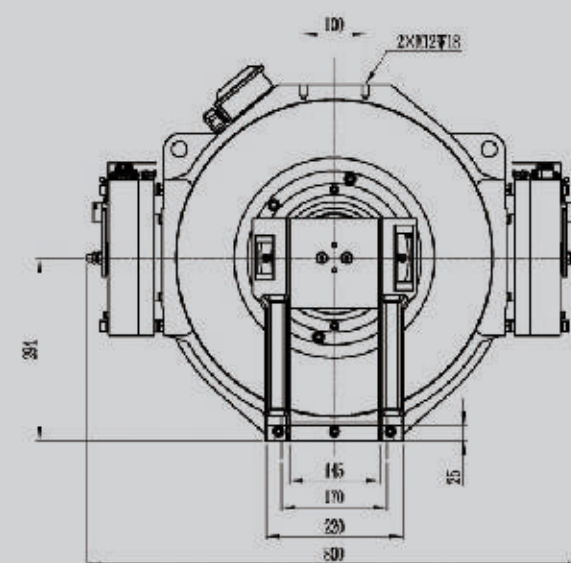
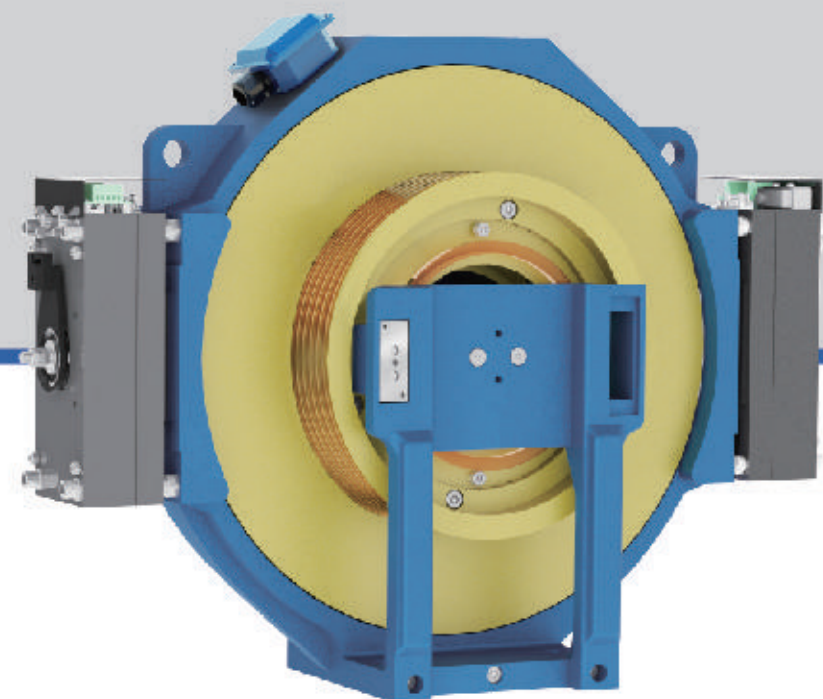

安装尺寸图  
DIMENSIONS

MCB100

## 规格表/SPEC.SHEET

型号	规格	额定载重	额定梯速	曳引轮节径	曳引轮绳槽	电源电压	额定电流	额定功率	额定转速	额定频率	额定转矩	电机极数	推荐切口角
Type	Spec	Elv Load	Elv Speed	Sheave Dia	Sheave Groove	Voltage	Current	Power	Speed	Freq	Torque	Poles	Undercut Angle
		kg	m/s	mm		V	A	kW	r/min	Hz	N·m		°
MCB100	320-0.5	320	0.5	320	3 × Φ8 × 12	380	4	1	60	16	160	32	
MCB100	320-0.63	320	0.63	320	3 × Φ8 × 12	380	4	1.3	75	20	160	32	
MCB100	320-1.0	320	1.0	320	3 × Φ8 × 12	380	5	2	119	31.7	160	32	
MCB100	320-1.5	320	1.5	320	3 × Φ8 × 12	380	8	3	179	47.7	160	32	
MCB100	320-1.6	320	1.6	320	3 × Φ8 × 12	380	8	3.2	191	50.9	160	32	
MCB100	320-1.75	320	1.75	320	3 × Φ8 × 12	380	8	3.5	209	55.7	160	32	
MCB100	450-0.5	450	0.5	320	4 × Φ8 × 12	380	5	1.4	60	16	230	32	
MCB100	450-0.63	450	0.63	320	4 × Φ8 × 12	380	5	1.8	75	20	230	32	
MCB100	450-1.0	450	1.0	320	4 × Φ8 × 12	380	7	2.9	119	31.7	230	32	
MCB100	450-1.5	450	1.5	320	4 × Φ8 × 12	380	12	4.3	179	47.7	230	32	
MCB100	450-1.6	450	1.6	320	4 × Φ8 × 12	380	12	4.6	191	50.9	230	32	
MCB100	450-1.75	450	1.75	320	4 × Φ8 × 12	380	12	5	209	55.7	230	32	
MCB100	630-0.5	630	0.5	320	5 × Φ8 × 12	380	7	2	60	16	320	32	
MCB100	630-0.63	630	0.63	320	5 × Φ8 × 12	380	7	2.5	75	20	320	32	
MCB100	630-1.0	630	1.0	320	5 × Φ8 × 12	380	10	4	119	31.7	320	32	
MCB100	630-1.5	630	1.5	320	5 × Φ8 × 12	380	16	6	179	47.7	320	32	
MCB100	630-1.6	630	1.6	320	5 × Φ8 × 12	380	16	6.4	191	50.9	320	32	
MCB100	630-1.75	630	1.75	320	5 × Φ8 × 12	380	16	7	209	55.7	320	32	

电源电压	Voltage	380V
悬挂比	Roping	2:1
绕绳方式	Wrap	单绕(Single)
额定载重	Elv. Load	(320 ~ 630)kg
电梯速度	Elv. Speed	(0.5 ~ 1.75)m/s
曳引轮节径	Sheave Diam	320mm
工作制	Duty	S5 - 40%ED
起动次数	Starts Per Hour	240st/h
最大轴静载	Max. Static Load	2500kg
自重	Weight	210kg
制动器	Brake	DC110V 2×1.3A
防护等级	IP Code	IP41
绝缘等级	Ins. Class	F

### 注 Remark:

- 1、本机型用于无机房。 The machine is used for machine room.
- 2、样本切口角为推荐值,可根据实际工况要求选择切口角度。 The above is recommended value of cut angle, it's optional according to practical condition.
- 3、本机型标配方波磁环编码器,可选配正弦磁环编码器。 Square wave magnetic loop encoder is the standard configuration for this model. Sin&cos magnetic loop encoder is optional if require.

# MCB200

Permanent Magnet Synchronous Gearless Traction Machine  
永磁同步无齿轮曳引机

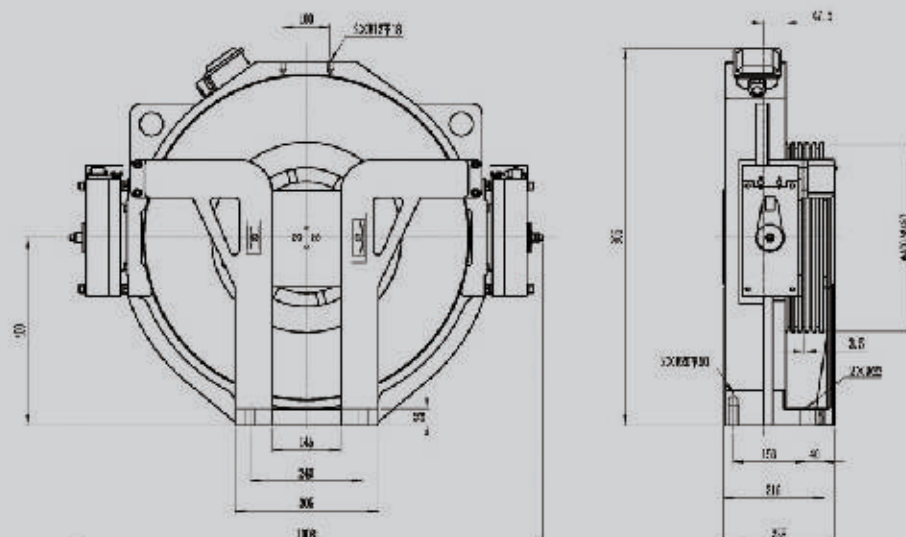
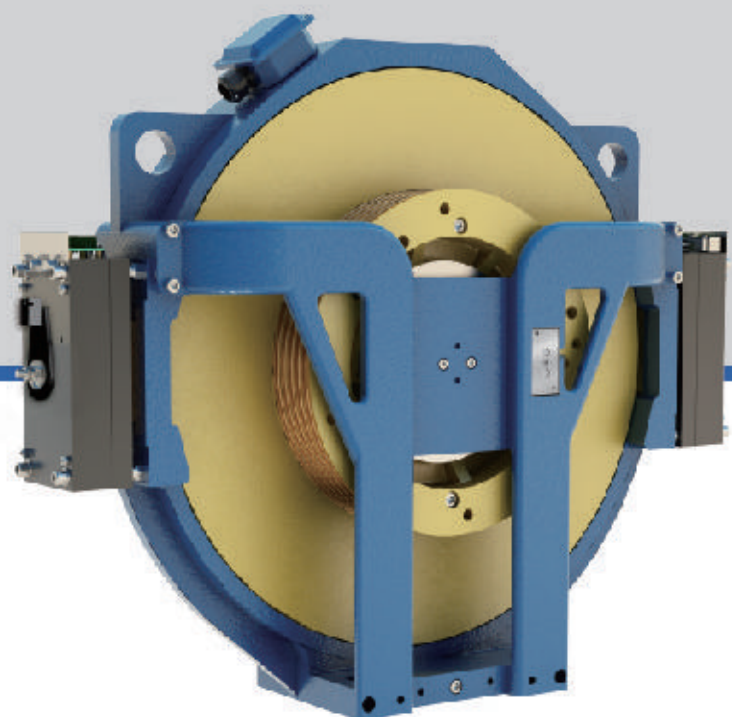

安装尺寸图  
DIMENSIONS

MCB200

## 规格表/SPEC.SHEET

型号 Type	规格 Spec	额定载重 Elv Load kg	额定梯速 Elv Speed m/s	曳引轮节径 Sheave Dia mm	曳引轮绳槽 Sheave Groove	电源电压 Voltage V	额定电流 Current A	额定功率 Power kW	额定转速 Speed r/min	额定频率 Freq Hz	额定转矩 Torque N·m	电机极数 Poles	推荐切口角 Undercut Angle °
MCB200	630-0.5	630	0.5	400	4×Φ10×15	380	6	2.2	48	19.2	430	48	
MCB200	630-0.63	630	0.63	400	4×Φ10×15	380	6	2.7	60	24.0	430	48	
MCB200	630-1.0	630	1.0	400	4×Φ10×15	380	10	4.3	95	38.0	430	48	
MCB200	630-1.5	630	1.5	400	4×Φ10×15	380	16	6.4	143	57.2	430	48	
MCB200	630-1.6	630	1.6	400	4×Φ10×15	380	16	6.9	153	61.2	430	48	
MCB200	630-1.75	630	1.75	400	4×Φ10×15	380	16	7.5	167	66.8	430	48	
MCB200	800-0.5	800	0.5	400	5×Φ10×15	380	8	2.7	48	19.2	540	48	
MCB200	800-0.63	800	0.63	400	5×Φ10×15	380	8	3.4	60	24.0	540	48	
MCB200	800-1.0	800	1.0	400	5×Φ10×15	380	12	5.4	95	38.0	540	48	
MCB200	800-1.5	800	1.5	400	5×Φ10×15	380	20	8.1	143	57.2	540	48	
MCB200	800-1.6	800	1.6	400	5×Φ10×15	380	20	8.7	153	61.2	540	48	
MCB200	800-1.75	800	1.75	400	5×Φ10×15	380	20	9.4	167	66.8	540	48	
MCB200	1000-0.5	1000	0.5	400	5×Φ10×15	380	10	3.2	48	19.2	640	48	
MCB200	1000-0.63	1000	0.63	400	5×Φ10×15	380	10	4	60	24.0	640	48	
MCB200	1000-1.0	1000	1.0	400	5×Φ10×15	380	15	6.4	95	38.0	640	48	
MCB200	1000-1.5	1000	1.5	400	5×Φ10×15	380	22	9.6	143	57.2	640	48	
MCB200	1000-1.6	1000	1.6	400	5×Φ10×15	380	26	10.3	153	61.2	640	48	
MCB200	1000-1.75	1000	1.75	400	5×Φ10×15	380	26	11.2	167	66.8	640	48	
MCB200	630-0.5	630	0.5	480	4×Φ10×15	380	8	2.1	40	16	510	48	
MCB200	630-0.63	630	0.63	480	4×Φ10×15	380	8	2.7	50	20	510	48	
MCB200	630-1.0	630	1.0	480	4×Φ10×15	380	11	4.3	80	32	510	48	
MCB200	630-1.5	630	1.5	480	4×Φ10×15	380	18	6.4	119	47.6	510	48	
MCB200	630-1.6	630	1.6	480	4×Φ10×15	380	18	6.8	127	50.8	510	48	
MCB200	630-1.75	630	1.75	480	4×Φ10×15	380	18	7.4	139	55.6	510	48	
MCB200	800-0.5	800	0.5	480	5×Φ10×15	380	10	2.7	40	16	640	48	
MCB200	800-0.63	800	0.63	480	5×Φ10×15	380	10	3.4	50	20	640	48	
MCB200	800-1.0	800	1.0	480	5×Φ10×15	380	14	5.4	80	32	640	48	
MCB200	800-1.5	800	1.5	480	5×Φ10×15	380	22	8	119	47.6	640	48	
MCB200	800-1.6	800	1.6	480	5×Φ10×15	380	22	8.5	127	50.8	640	48	
MCB200	800-1.75	800	1.75	480	5×Φ10×15	380	22	9.3	139	55.6	640	48	
MCB200	1000-0.5	1000	0.5	480	5×Φ10×15	380	11	3.2	40	16	760	48	
MCB200	1000-0.63	1000	0.63	480	5×Φ10×15	380	11	4	50	20	760	48	
MCB200	1000-1.0	1000	1.0	480	5×Φ10×15	380	16	6.4	80	32	760	48	
MCB200	1000-1.5	1000	1.5	480	5×Φ10×15	380	27	9.5	119	47.6	760	48	
MCB200	1000-1.6	1000	1.6	480	5×Φ10×15	380	27	10.1	127	50.8	760	48	
MCB200	1000-1.75	1000	1.75	480	5×Φ10×15	380	27	11.1	139	55.6	760	48	

注 Remark:

1. 本机用于无机房。The machine is used for machine roomless.
2. 样本切口角为推荐值, 可根据实际工况要求选择切口角度。The above is recommended value of cut angle, it's optional according to practical condition.
3. 本机标配方波磁环编码器, 可选配正弦磁环编码器。Square wave magnetic loop encoder is the standard configuration for this model. Sin&cos magnetic loop encoder is optional if require.

电源电压	Voltage	380V
悬挂比	Roping	2:1
绕绳方式	Wrap	单绕(Single)
额定载重	Elv. Load	(630 ~ 1000)kg
电梯速度	Elv. Speed	(0.5 ~ 1.75)m/s
曳引轮节径	Sheave Diam	400mm / 480mm
工作制	Duty	S5 - 40%ED
起动次数	Starts Per Hour	240st/h
最大轴静载	Max. Static Load	3000kg
自重	Weight	370kg
制动器	Brake	DC110V 2×1.3A
防护等级	IP Code	IP41
绝缘等级	Ins. Class	F

# MQ270

Permanent Magnet Synchronous Positive Drive Machine  
永磁同步强制驱动主机

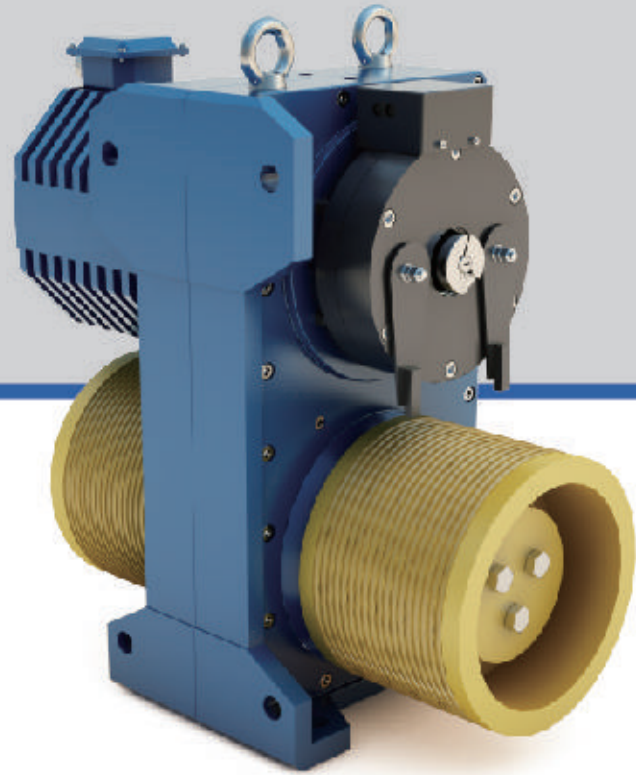

安装尺寸图  
DIMENSIONS

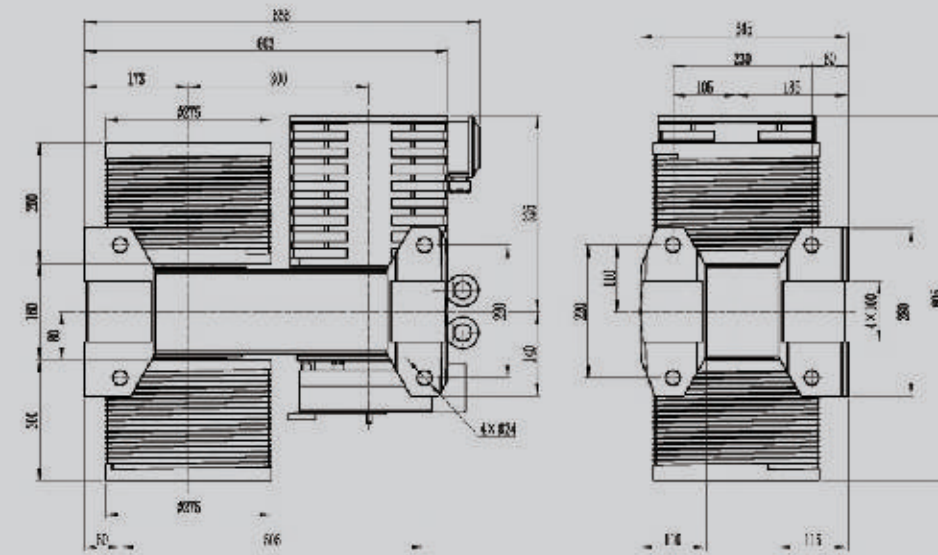

提升高度推荐表  
Travelling recommendation table

钢丝绳直径/mm Rope diameter	推荐高度 /m Travelling recommendation
8	≤12

MQ270

## 规格表/SPEC.SHEET

型号	额定载重+轿厢	额定梯速	减速比	曳引轮节径	电源电压	电机转速	电机频率	电机电流	电机功率	电机转矩	曳引轮转矩	电机极数
Type	Load(P+Q)	Elv Speed	Reduction Ratio	Sheave Dia	Voltage	Speed	Freq	Current	Power	Torque	SheaveTorque	Poles
	kg	m/s		mm	V	r/min	Hz	A	kW	N·m	N·m	
MQ270	600	0.3	1:8	270	220/380	170	22.7	7	1.8	100	800	16
MQ270	700	0.3	1:8	270	220/380	170	22.7	8	2.1	120	960	16
MQ270	800	0.3	1:8	270	220/380	170	22.7	9	2.4	130	1040	16
MQ270	900	0.3	1:8	270	220/380	170	22.7	11	2.7	150	1200	16
MQ270	1000	0.3	1:8	270	220/380	170	22.7	12	3	170	1360	16
MQ270	600	0.4	1:8	270	220/380	226	30.1	10	2.4	100	800	16
MQ270	700	0.4	1:8	270	220/380	226	30.1	11	2.8	120	960	16
MQ270	800	0.4	1:8	270	220/380	226	30.1	12	3.2	130	1040	16
MQ270	900	0.4	1:8	270	220/380	226	30.1	14	3.5	150	1200	16
MQ270	1000	0.4	1:8	270	220/380	226	30.1	16	4	170	1360	16

注 Remark:

- 1、本机用于无机房。The machine is used for machine roomless.
- 2、标配提升高度≤12米，可非标提升高度≤15米。  
The travelling height shall be less than 12m as standard. Less than 15m is optional while customized.
- 3、可选配φ10mm钢丝绳，提升高度比φ8mm的钢丝绳降低3米。  
Φ10mm rope is optional, the travelling height will be 3m lower when apply for Φ8mm rope.

电源电压	Voltage	220V/380V
额定载重+轿厢	Load(P+Q)	≤1000kg
电梯速度	Elv. Speed	(0.3 ~ 0.4)m/s
曳引轮节径	Sheave Diam	275mm
工作制	Duty	S5 - 40%ED
起动次数	Starts Per Hour	180st/h
最大轴静载	Max. Static Load	2500kg
自重	Weight	280kg
制动器	Brake	DC110V 2.4A
防护等级	IP Code	IP41
绝缘等级	Ins. Class	F

## 制动器 / BRAKE

EMC鼓式制动器(MCG用)  
EMC drum Brake for MCG



EMK块式制动器(MCK/MCB用)  
EMK block Brake for MCK/MCB



EMM盘式制动器(MONA/MGD/MQ用)  
EMM disk Brake for MONA/MGD/MQ



EMD蝶式制动器(MDD用)  
EMD caliper Brake for MDD



注 Remark:

1. 样本中制动器电压电流值为驱动所需电压电流的总值。  
The value of brake voltage and current is the total value.
2. 制动力动作方式满足上行超速保护装置对制动器要求。  
Braking mode is suitable for overspeed protection device.

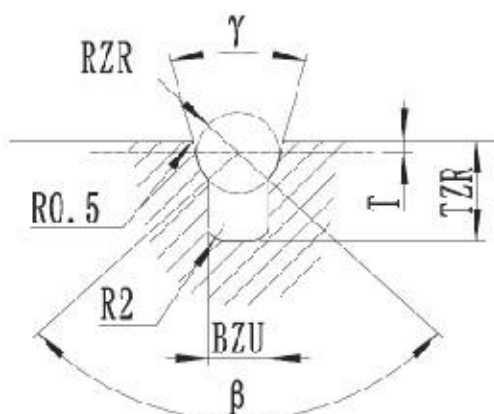

带切口的半圆槽  
Semi-circular undercut groove

## 曳引轮绳槽 / SHEAVE GROOVE

注 Remark:

1. 如需校核曳引力, 请提供电梯参数。  
For checking traction force, please provide elevator parameters.
2. 可以根据用户要求加工曳引轮槽形。  
The groove shape can be customized.

## 编码器 / ENCODER

	型式	分辨率	电源
	Type	Pulse	Source
标配 Standard	Sin/Cos	2048 P/R	5VDC
选配 Option	ABZ	8192P/R	5VDC

注 Remark:

1. 可以根据用户要求选配。Encoder type can be customized.

# 科技改变未来

# 服务没有极限