



EC type-examination certificate

Certificate no.: ABV 766/2

Notified body: TÜV SÜD Industrie Service GmbH
Zertifizierungsstelle für Aufzüge und Sicherheitsbauteile
Westendstr. 199
80686 München - Germany

**Applicant/
Certificate holder:** Chr. Mayr GmbH & Co. KG
Eichenstr. 1
87665 Mauerstetten - Germany

Date of application: 2009-05-19

Manufacturer: Chr. Mayr GmbH & Co. KG
Eichenstr. 1
87665 Mauerstetten – Germany

Mayr Power Transmission Zhangjiagang Co.,Ltd.
No. 3 Factory, No. 16 Changxing road,
215600 Zhangjiagang, P.R. China R

Product: Braking device, acting on the shaft of the traction sheave, as part of the protection device against overspeed for the car moving in upwards direction

Type: RSR/8010._____, Size 200, 400, 600, 800, 1000

Test laboratory: TÜV SÜD Industrie Service GmbH
Prüflaboratorium für Produkte der Fördertechnik
Prüfbereich Aufzüge und Sicherheitsbauteile
Westendstr. 199
80686 München - Germany

**Date and
number of test report:** 2009-09-16
766/2

EC-directive: 95 / 16 / EC

Result: The safety component conforms to the directive's essential safety requirements for the respective scope of application stated on page 1 and 2 of the annex to this EC type-examination certificate.

Date of issue: 2009-09-16

Certification body for lifts and safety components
Identification number: 0036

Dieter Roas
Dieter Roas



Annex to the EC type-examination certificate no. ABV 766/2 dated 2009-09-16

1. Scope of Application

- 1.1 Permissible brake moment, maximum tripping rotary speed and maximum rated rotary speed of the traction sheave when the brake device acts on the shaft of the traction sheave while the car is moving upward

Seize	Permissible brake moment (Nm)	Max. tripping rotary speed of traction sheave (min ⁻¹)	Max. rated rotary speed of traction sheave (min ⁻¹)
200	200 – 560	811	705
400 „short“	420 – 840	708	616
400 „long“	750 – 1200	1011	879
600	1000 – 1600	500	435
800	1300 – 1900	400	348
1000	1840 – 2400	400	348

- 1.2 Maximum tripping speed of the overspeed governor and maximum rated speed

The maximum tripping speed and the maximum rated speed must be calculated on the basis of the traction sheaves maximum tripping rotary speed and maximum rated rotary speed as outlined in sections 1.1 taking into account traction-sheave diameter and car suspension.

$$v = \frac{D \times \pi \times n}{60 \times i}$$

v = speed (m/s)
 D = Diameter of the traction sheave from rope's centre to rope's centre (m)
 π = 3,14
 n = Rotary speed (min⁻¹)
 i = Ratio of the car suspension

2. Conditions

- 2.1 Since the brake device represents only a part of the protection device against overspeed for the car moving in upwards direction an overspeed governor as per EN 81-1, paragraph 9.9 must be used to monitor the upward speed and the brake device must be triggered (engaged) via the overspeed governor's electric safety device.

Alternatively, the speed may also be monitored and the brake device engaged by a device other than an overspeed governor as per paragraph 9.9 if the device shows the same safety characteristics and has been type tested.

- 2.2 In order to recognise the loss of redundancy the movement of each brake circuit (each single brake) is to be monitored separately and directly (e.g. by micro switches). If a brake circuit fails to engage (close) while the lift machine is at standstill, next movement of the lift must be prevented.
- 2.3 In cases where the lift machine moves despite the brake being engaged (closed), the lift machine must be stopped at the next operating sequence at the latest and the next movement of the lift must be prevented. (The car may, for example, be prevented from traveling by querying the position of the micro switch which is used to monitor the mechanical movement of the brake circuits, should both brake circuits fail to open).

- 2.4 According to EN 81-1, paragraph 9.10.4 d a braking device must act directly on the traction sheave or on the same shaft on which the traction sheave is situated in the immediate vicinity thereof.

If the braking device does not act in the immediate vicinity of the traction sheave on the same shaft on which the traction sheave is situated, the standard is not complied with. In cases involving shaft failure in the extended area between the traction sheave and the braking device, safety would no longer be ensured by the latter if the lift car made an uncontrolled upward movement.

Shaft failure in the extended area must therefore be ruled out by appropriate design and sufficient dimensioning. In order to eliminate or reduce influencing factors which may lead to failure wherever possible, the following requirements must be satisfied:

- Minimization of bending length between traction sheave and braking device or traction sheave and the next bearing (the next bearing must form part of the drive unit)
- Static defined bearing (e. g. 2-fold borne shaft) otherwise measures are required to obtain a defined loading
- As far as possible, prevention of a reduction in load-bearing capacity in the area of reversed bending stress (reduction in load-bearing capacity caused, for example, by stress concentration and cross-sectional reductions)
- Between traction sheave and braking device the shaft must be continuous (made from one piece)
- Cross-sectional influences on the shaft are only permitted if they act on the following connections: traction sheave – shaft, braking device – shaft, torque of the transmitting component – shaft (situated between traction sheave and braking device).

The manufacturer of the drive unit must provide calculation evidence that the connection braking device – shaft, traction sheave - shaft and the shaft itself is sufficiently safe. If necessary, evidence must be provided for the intended measures, too (see static undefined bearing).

The calculation evidence must be enclosed with the technical documentation of the lift.

3. Remarks

- 3.1 A code number for the brake moment effectively adjusted will be marked at the first blank in the type designation 8010. __ __ __ __ within the permissible scope of application. A code number for design characteristics which are not directly part of the type-examination will be marked at the rest of the blanks (e. g. in the second blank: with flange plate, in the third blank: with hand release; in the fourth blank: release control and/or wear control; in the fifth blank: characteristics for electrical connection).
- 3.2 The permissible brake moments must be applied to the lift system in such a manner that they do not decelerate more than $1 g_n$, if the empty car is moving upwards.
- 3.3 In the scope of this type-examination it was found out, that the brake device also functions as a brake for normal operation, is designed as a redundant system and therefore meets the requirements to be used also as a part of the protection device against overspeed for the car moving in upwards direction.
- This type examination only refers to the requirements pertaining to brake devices as per EN 81-1, paragraph 9.10.
- Checking whether the requirements as per paragraph 12.4 have been complied with is not part of this type examination.
- 3.4 In order to provide identification, information about the basic design and its functioning and to show which parts have been tested pertaining to the tested and approved type, drawing no. E 028 01 000 000 1 61 dated 21 July 2009 is to be enclosed with the EC type-examination certificate and the Annex thereto. The installation conditions and connection requirements are presented or described in separate documents (e.g. assembly and operating instructions).
- 3.5 The EC type-examination certificate may only be used in connection with the pertinent Annex.

Ansicht/
viex X/
vue X

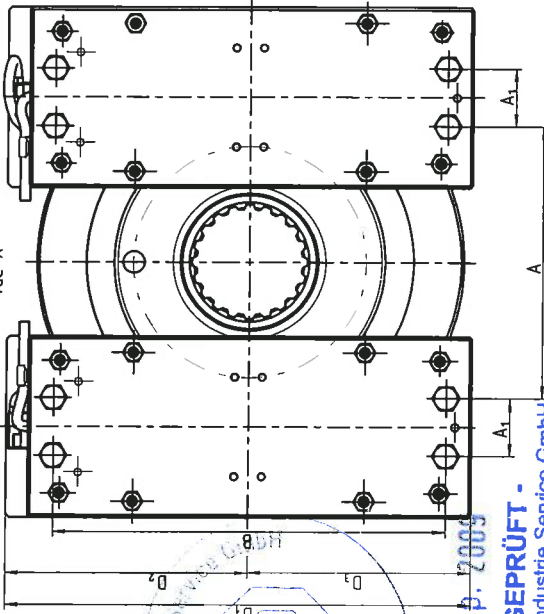

TÜV SÜD Industrie Service GmbH
Zentralbereich Fördertechnik-Sonderbauten
Abteilung Aufzüge und Sicherheitsbauteile
Westendstr. 199, D-81686 München
Der Sachverständigen
Nagel

16. Sep. 2009

- GEPRÜFT -

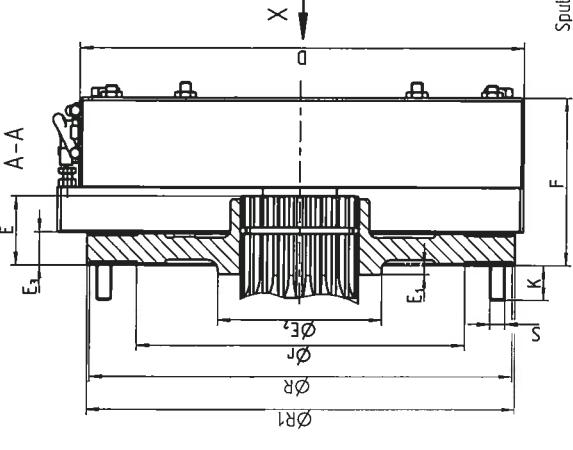
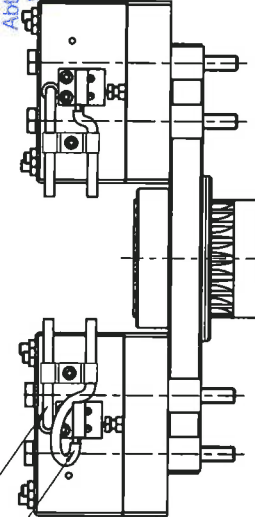
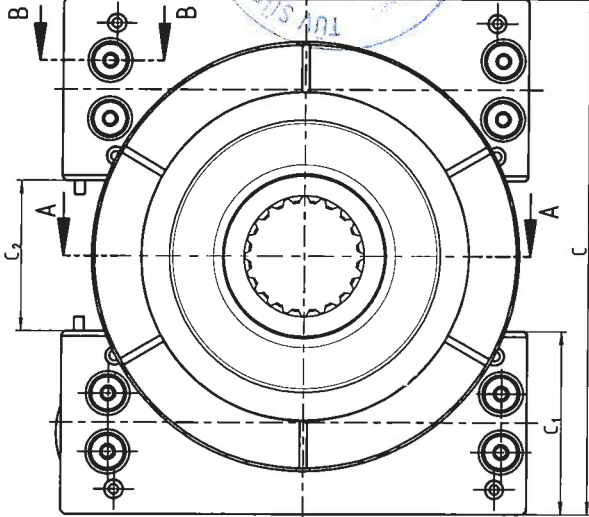

- 1) = Maße variabel, alternative Befestigungsschrauben
mit entsprechendem Festigkeitsnachweis/
dimensions variable, alternative bolts
with relevant stressability proof/
Dimensions variables, autres vis de fixation
possibles avec contrôle de qualité correspondant.
2) = alternative Verzahnungen mit
entsprechendem Festigkeitsnachweis/
relevant stressability proof/
Autres cameures possibles avec
contrôle de qualité correspondant
3) = alternative Rotordurchmesser mit
entsprechendem Befestigungsnachweis/
relevant calculation of spring configuration/
Autres diamètres de rotor possibles avec
contrôle des ressorts correspondant

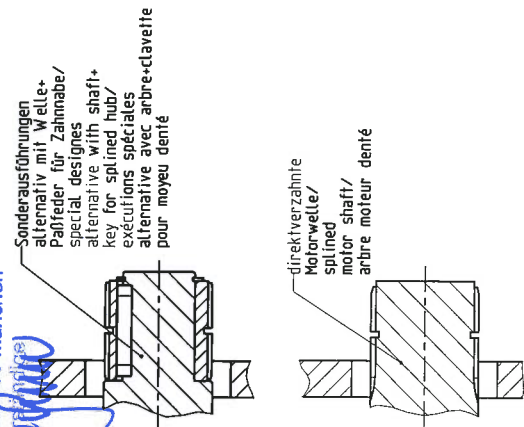

Größe/ size/ taille	Bremsmomente/ braking torque/ couples de freinage	max. Auslaste Drehzahl/ max. speed/ vitesse max.	1) elektr. Leistung/ input power/ puissance électr.	2) Verzahnungen der Motorwelle DIN 5460 / Abovements tech Cameures préférentielles de l'arbre du moteur	A	A1	B	C	C1	C2	D	D1	D2	D3	E	E1	E2	E3	F	F2	K	R	R1	S	
200	2x100 bis 2x280@	811	2x 74	60 x 2.5 x 22 65 x 3 x 20 67 x 3 x 21	138	32	216	270	100	70	244	256	134	122	36	5	90	18	86.1	19.1	14	180	232	235	M8
400 Kurz	2x210 bis 2x420	708	2x 85	65 x 3 x 20 67 x 3 x 21 72 x 3 x 22	153	42	238	315	120	75	268	280	146	134	35	17	90	18	96.1	19.1	14	200	250	253	M10
400 Lang	2x375 bis 2x600	1011	2x 89	72 x 3 x 22 82 x 3 x 26 90 x 3 x 28	128	42	258	290	120	50	290	303	157	146	35	17	90	18	96.1	19.1	19	200	250	253	M10
600	2x500 bis 2x800	500	2x 86	72 x 3 x 22 82 x 3 x 26 90 x 3 x 28	165	50	264	355	140	75	298	311	162	149	41	25	110	18	101.1	24.1	19	220	277	281	M12
800	2x650 bis 2x950	400	2x 118	82 x 3 x 26 90 x 3 x 28 98 x 4 x 23	169	56	300	375	150	75	336	349	181	168	41	20	124	20	106.1	29.1	22	250	311	315	M12
1000	2x920 bis 2x1200	400	2x 121	90 x 3 x 28 98 x 4 x 23 115.9 x 5 x 22	175	60	342	395	160	75	380	393	203	190	41	24	135	20	108.1	29.1	22	280	344	348	M16

perforierter Stahlblech / perforated steel plate

Art/Nr.-Nr. / Art/Nr.-No. : 1.2

Typ / Type : RSR Baugröße 200 - 1000

Größe / Size : Type 8010

Material / Material : Fe 0.07 C

Norm / Norm : EN 10204

Produktions-Nr. / Production No. : E02801000000161

Bestell-Nr. / Order No. : 1788357

Hersteller / Manufacturer : mayr

Produktions-Nr. / Production No. : 1.2

Größe / Size : Type 8010

Material / Material : Fe 0.07 C

Norm / Norm : EN 10204

Produktions-Nr. / Production No. : E02801000000161

Bestell-Nr. / Order No. : 1788357